

Measure table



Contents

FLAT GASKETS: revoseal - Non Asbestos CF1000 - Graphite CF 2000 SGL - PTFE CF 3000 - Elastomer Gasket	3
Gasket profiles	4
Flat Gasket dimensional table according to Standard ASME B16.21	5
Flat Gasket dimensional table according to Standard ASME B16.47 A Series and B Series	7
Flat Gasket dimensional table according to Standard EN1514-1	8
SPIRAL WOUND GASKETS: Spiral Wound Cf 4000 - revoseal	11
Gasket profiles	12
Ring Colour Table for spiral wound Gasket according to Standard ASME B16.20	13
Spiral wound Gasket weights table	13
Spiral wound Gasket dimensional table according to Standard ASME B16.20	14
Spiral wound Gasket dimensional table according to Standard ASME B16.47 Series A (formerly MSS SP44)	15
Spiral wound Gasket dimensional table according to Standard ASME B16.47 Series B (formerly API 605)	16
Spiral wound Gasket dimensional table according to Standard ASME B16.20	17
Spiral wound Gasket dimensional table according to Standard EN1514-2	18
Spiral wound Gasket dimensional table according to Standard DIN 2691/ 2692	19
METAL JACKETED GASKETS: Metal Jacketed CF 5000	20
Metal Jacketed Gasket dimensional table according to Standard ASME B16.20	21
Metal Jacketed Gasket dimensional table according to Standard EN1514-4	22
CAMPROFILE GASKETS: Camprofile CF 6000 - revoseal	23
Gasket profiles	24
Camprofile Gasket dimensional table according to Standard ASME B16.20	25
Camprofile Gasket dimensional table according to Standard EN 1514-6	28
RING JOINT GASKETS: Ring Joint CF 7000	29
Ring Joint Gasket Material hardness table according to Standard ASME B16.20	30
Type R Ring Joint gasket dimensional table according to standard ASME B16.47 Series A and API 6B	31
Type RX Ring Joint gasket dimensional table according to standard ASME B16.47 API 6A	35
Type BX Ring Joint gasket dimensional table according to standard ASME B16.47 API 6A	36
INSULATION SOLUTIONS: Insulation Kit - Insulation Kit FSA - Anticorrosion KIT	38
Insulation Kit dimensional table for flanges according to Standard ANSI B16.5	39

Flat gasket

revo seal, Non Asbestos CF1000, Graphite CF 2000 Sgl, PTFE CF 3000, Elastomer Gasket



REVOSEAL



**SERIES 1000
NON ASBESTOS**



ELASTOMER



**SERIES 2000
GRAPHITE SGL**



**SERIES 3000
PTFE**

Gasket profiles

REVOSEAL

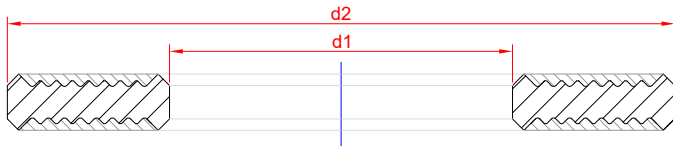
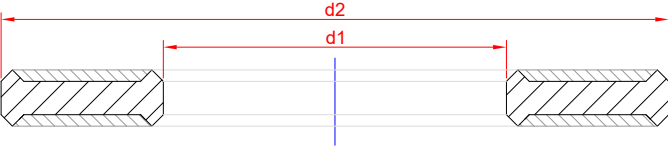

RAISED FACE FLANGES RF

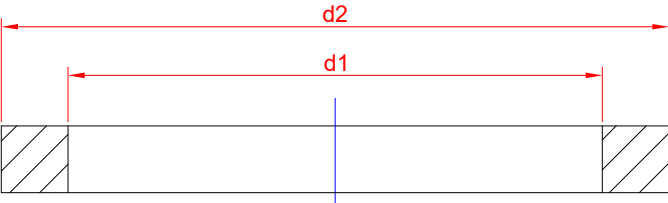

FULL FACE FLANGES FF

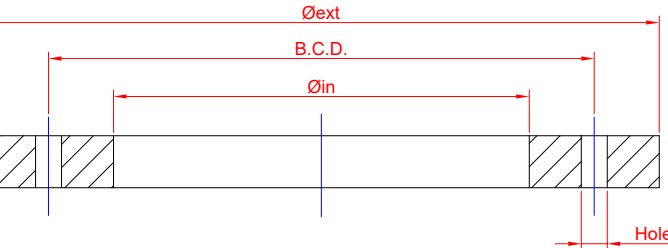

Flat Gasket dimensional table according to Standard ASME B16.21

Tolerances	up to Ø600mm	over Ø600mm
Inner diameter	±0,4mm	±0,3mm
Outer diameter	±0,4mm	±0,3mm

Raised Face Flanges RF							
Nominal diameter	d1	d2					
		class 150	class 300	class 400	class 600	class 900	class 1500
1/2"	21	48	54	54	54	64	64
3/4"	27	57	67	67	67	70	70
1"	33	67	73	73	73	79	79
1 1/4"	42	76	83	83	83	89	89
1 1/2"	48	86	95	95	95	98	98
2"	60	105	111	111	111	143	143
2 1/2"	73	124	130	130	130	165	165
3"	89	137	149	149	149	168	175
3 1/2"	102	162	165	162	162	-	-
4"	114	175	181	178	194	206	210
5"	141	197	216	213	241	248	254
6"	168	222	251	248	267	289	283
8"	219	279	308	305	321	359	352
10"	273	340	362	359	400	435	435
12"	324	410	422	419	457	498	521
14"	356	451	486	483	492	521	578
16"	406	514	540	537	565	575	641
18"	457	549	597	594	613	638	705
20"	508	606	654	648	683	699	756
22"	-	660	705	701,7	704,9	-	-
24"	610	718	775	768	791	838	902

Full Face flanges FF RATING 125 - 150					
Nominal diameter	Øin	Øext	B.C.D.	Holes	
				Ø	N
1/2"	21	89	60,3	16	4,0
3/4"	27	98	69,9	16	4,0
1"	33	108	79,4	16	4,0
1 1/4"	42	117	88,9	16	4,0
1 1/2"	48	127	98,4	16	4,0
2"	60	152	120,7	19	4,0
2 1/2"	73	178	139,7	19	4,0
3"	89	191	152,4	19	4,0
3 1/2"	102	216	177,8	19	8
4"	114	229	190,5	19	8
5"	141	254	215,9	22,2	8
6"	168	279	241,3	22,2	8
8"	219	343	298,4	22,2	8
10"	273	406	362	25,4	12
12"	324	483	431,8	25,4	12
14"	356	533	476,3	28,6	12
16"	406	597	539,8	28,6	16
18"	457	635	577,9	31,7	16
20"	508	699	635	31,7	20
22"	-	-	-	-	-
24"	610	813	749,3	34,9	20

Flat Gasket dimensional table according to Standard ASME B16.21

Tolerances	up to Ø600mm	over Ø600mm
Inner diameter	±0,4mm	±0,3mm
Outer diameter	±0,4mm	±0,3mm

Full Face flanges FF RATING 300					
Nominal diameter	d1	d2	c.f.	No. Holes	
				Ø	N
1/2"	21,4	95,5	66,7	16,0	4,0
3/4"	27	117,5	82,5	19,0	4,0
1"	33,3	124,0	88,9	19,0	4,0
1 1/4"	42,0	133,5	98,4	19,0	4,0
1 1/2"	48,4	156,0	114,3	22,0	4,0
2"	60,3	165,0	127,0	19,0	8,0
2 1/2"	73,0	190,5	149,2	22,0	8,0
3"	88,9	210,0	168,3	22,0	8,0
3 1/2"	101,6	229	184,1	22	8
4"	114,3	228,5	190,5	22,0	8,0
5"	141,3	279,4	234,9	22,0	8,0
6"	168,3	317,5	269,9	22,0	12,0
8"	219,1	381,0	330,2	25,0	12,0
10"	273,0	444,5	387,3	25,0	16,0
12"	323,8	520,7	450,8	32,0	16,0
14"	355,6	584,2	514,3	32,0	20,0
16"	406,4	647,7	571,5	35,0	20,0
18"	457,2	711,2	628,6	35,0	24,0
20"	508,0	774,7	685,8	35,0	24,0
22"	-	838,2	742,9	42	24
24"	609,6	914,4	812,8	42,0	24,0

Large Male & Female LMF		
Nominal diameter	d1	d2
1/2"	21,4	34,9
3/4"	27	42,9
1"	33,3	50,8
1 1/4"	42	63,5
1 1/2"	48,4	73
2"	60,3	92
2 1/2"	73	104,8
3"	88,9	127
3 1/2"	101,6	139,7
4"	114,3	157,2
5"	141,3	185,7
6"	168,3	215,9
8"	219,1	269,9
10"	273	323,8
12"	323,8	381
14"	355,6	412,7
16"	406,4	469,9
18"	457,2	533,4
20"	508	584,2
22"	-	-
24"	609	692,1

Large Tongue and Groove Flanges LTG		
Nominal diameter	d1	d2
1/2"	25,4	34,9
3/4"	33,3	42,9
1"	38,1	50,8
1 1/4"	47,6	63,5
1 1/2"	54	73
2"	73	92
2 1/2"	85,7	104,8
3"	107,9	127
3 1/2"	120,6	139,7
4"	131,8	157
5"	160,3	185,7
6"	190,5	215,9
8"	238,1	269,9
10"	285,7	323,8
12"	342,9	381
14"	374,6	412,7
16"	425,4	469,9
18"	488,9	533,4
20"	533,4	584,2
-	-	-
24"	641,3	692,1

Small Tongue and Groove flanges STG		
Nominal diameter	d1	d2
1/2"	25,4	34,9
3/4"	33,3	42,9
1"	38,1	47,6
1 1/4"	47,6	57,5
1 1/2"	54	63,5
2"	73	82,5
2 1/2"	85,7	92,5
3"	107,9	117,5
3 1/2"	120,6	130,2
4"	131,8	144,5
5"	160,3	173
6"	190,5	203,2
8"	238,1	254
10"	285,7	304,8
12"	342,9	361,9
14"	374,6	393,6
16"	425,4	447,7
18"	488,9	511,2
20"	533,4	558,8
22"	-	-
24"	641,3	666,7

Flat Gasket dimensional table according to Standard EN1514-1

Tolerances	up to Ø600mm	over Ø600mm
Inner diameter	±0,4mm	±0,3mm
Outer diameter	±0,4mm	±0,3mm

Large Male & Female LMF			
Nominal diameter	PN 6	PN 10/100	
	d2 (mm)	d1 (mm)	d2 (mm)
DN 10	30	24	34
DN 15	35	29	39
DN 20	42	36	50
DN 25	49	43	57
DN 32	61	51	65
DN 40	68	61	75
DN 50	81	73	87
DN 60	-	-	-
DN 65	101	95	109
DN 80	117	106	120
DN 100	137	129	149
DN 125	165	155	175
DN 150	192	183	203
DN 200	249	239	259
DN 250	304	292	312
DN 300	354	343	363
DN 350	401	395	421
DN 400	451	447	473
DN 450	505	497	523
DN 500	555	549	575
DN 600	655	649	675
DN 700	760	751	777
DN 800	865	856	882
DN 900	965	961	987
DN 1000	1062	1061	1092
DN 1100	-	-	-
DN 1200	-	-	-
DN 1400	-	-	-
DN 1500	-	-	-
DN 1600	-	-	-
DN 1800	-	-	-
DN 2000	-	-	-
DN 2200	-	-	-
DN 2400	-	-	-
DN 2600	-	-	-
DN 2800	-	-	-
DN 3000	-	-	-
DN 3200	-	-	-
DN 3400	-	-	-
DN 3600	-	-	-
DN 3800	-	-	-
DN 4000	-	-	-

Large Tongue & Groove LTG		
Nominal diameter	PN>=10	
	d1 (mm)	d2 (mm)
DN 10+R21:T62	24	34
DN 15	29	39
DN 20	36	50
DN 25	43	57
DN 32	51	65
DN 40	61	75
DN 50	73	87
DN 60	-	-
DN 65	95	109
DN 80	106	120
DN 100	129	149
DN 125	155	175
DN 150	183	203
DN 200	239	259
DN 250	292	312
DN 300	343	363
DN 350	395	421
DN 400	447	473
DN 450	497	523
DN 500	549	575
DN 600	649	675
DN 700	751	777
DN 800	856	882
DN 900	961	987
DN 1000	1061	1092
DN 1100	-	-
DN 1200	-	-
DN 1400	-	-
DN 1500	-	-
DN 1600	-	-
DN 1800	-	-
DN 2000	-	-
DN 2200	-	-
DN 2400	-	-
DN 2600	-	-
DN 2800	-	-
DN 3000	-	-
DN 3200	-	-
DN 3400	-	-
DN 3600	-	-
DN 3800	-	-
DN 4000	-	-

Flat Gasket dimensional table according to Standard EN1514-1

Tolerances	up to Ø600mm	over Ø600mm
Inner diameter	±0,4mm	±0,3mm
Outer diameter	±0,4mm	±0,3mm

Raised Face Flanges RF										
Nominal diameter	d1 (mm)	d2 (mm)							d1 (mm)	d2 (mm)
		PN 2.5	PN 6	PN 10	PN 16	PN 25	PN 40	PN 100		
DN 10	18	39	39	46	46	46	46	56	18	56
DN 15	22	44	44	51	51	51	51	61	21	61
DN 20	27	54	54	61	61	61	61	72	25	72
DN 25	34	64	64	71	71	71	71	82	30	82
DN 32	43	76	76	82	82	82	82	88	41	88
DN 40	49	86	86	92	92	92	92	103	47	103
DN 50	61	96	96	107	107	107	107	120	59	113
DN 60	72	106	106	117	117	117	117	///	68	123
DN 65	77	116	116	127	127	127	127	145	73	138
DN 80	89	132	132	142	142	142	142	155	86	148
DN 100	115	152	152	162	162	168	168	180	110	174
DN 125	141	182	182	192	192	194	194	217	135	210
DN 150	169	207	207	218	218	224	224	257	163	247
DN 200	220	262	262	273	273	284	290	324	210	309
DN 250	273	317	317	328	329	340	352	391	264	364
DN 300	324	373	373	378	384	400	417	458	314	424
DN 350	356	423	423	438	444	457	474	512	360	486
DN 400	407	473	473	489	495	514	546	627	415	543
DN 450	458	528	528	539	555	564	571	704	458	657
DN 500	508	578	578	594	617	624	628	813	508	764
DN 600	610	679	679	695	734	731	747	950	610	879
DN 700	712	784	784	810	804	833	852	-	712	988
DN 800	813	890	890	917	911	942	974	-	813	1108
DN 900	915	990	990	1017	1011	1042	1084	-	915	1220
DN 1000	1016	1090	1090	1124	1128	1154	1194	-	-	-
DN 1100	1120	-	-	1231	1228	1254	-	-	-	-
DN 1200	1220	1290	1307	1341	1342	1364	1395	-	-	-
DN 1400	1420	1490	1524	1548	1542	1578	1615	-	-	-
DN 1500	1520	-	-	1658	1654	1688	-	-	-	-
DN 1600	1620	1700	1724	1772	1764	1798	1830	-	-	-
DN 1800	1820	1900	1931	1972	1964	2000	-	-	-	-
DN 2000	2020	2100	2138	2182	2168	2230	-	-	-	-
DN 2200	2220	2307	2348	2384	2374	-	-	-	-	-
DN 2400	2420	2507	2558	2594	2584	-	-	-	-	-
DN 2600	2620	2707	2762	2794	2784	-	-	-	-	-
DN 2800	2820	2924	2972	3014	-	-	-	-	-	-
DN 3000	3020	3124	3182	3228	-	-	-	-	-	-
DN 3200	3220	3324	3382	-	-	-	-	-	-	-
DN 3400	3420	3524	3592	-	-	-	-	-	-	-
DN 3600	3620	3724	3804	-	-	-	-	-	-	-
DN 3800	3820	3931	-	-	-	-	-	-	-	-
DN 4000	4020	4131	-	-	-	-	-	-	-	-

Flat Gasket dimensional table according to Standard ASME B16.47 A Series and B Series

Tolerances	up to Ø600mm	over Ø600mm
Inner diameter	±0,4mm	±0,3mm
Outer diameter	±0,4mm	±0,3mm

Series A (formerly MSS SP44)						
Nominal diameter	d1	d2				
		class 150	class 300	class 400	class 600	class 900
26"	660	775	835	832	867	885
28"	711	832	899	892	914	945
30"	762	883	953	946	972	1010
32"	813	940	1006	1003	1022	1075
34"	864	991	1057	1054	1073	1135
36"	914	1048	1118	1118	1130	1200
38"	965	1111	1054	1073	1105	1200
40"	1016	1162	1114	1127	1156	1250
42"	1067	1219	1165	1178	1219	1300
44"	1118	1276	1219	1230	1270	1370
46"	1168	1327	1273	1289	1327	1435
48"	1219	1384	1324	1346	1391	1485
50"	1270	1435	1378	1403	1448	-
52"	1321	1492	1429	1454	1499	-
54"	1372	1549	1492	1518	1556	-
56"	1422	1607	1543	1568	1613	-
58"	1473	1664	1594	1619	1664	-
60"	1524	1715	1645	1683	1721	-

Series B (formerly API 605)						
Nominal diameter	d1	d2				
		class 75	class 150	class 300	class 400	class 600
26"	660	708	725	772	746	765
28"	711	753	776	826	800	819
30"	762	810	827	886	857	879
32"	813	860	881	940	911	933
34"	864	911	935	994	962	997
36"	914	973	987	1048	1022	1048
38"	965	1024	1045	1099	-	-
40"	1016	1075	1095	1149	-	-
42"	1067	1126	1146	1200	-	-
44"	1118	1181	1197	1251	-	-
46"	1168	1232	1256	1318	-	-
48"	1219	1283	1307	1368	-	-
50"	1270	1334	1357	1419	-	-
52"	1321	1387	1408	1470	-	-
54"	1372	1438	1464	1530	-	-
56"	1422	1459	1514	1594	-	-
58"	1473	1546	1580	1656	-	-
60"	1524	1597	1630	1705	-	-

Flat Gasket dimensional table according to Standard EN1514-1

Tolerances	up to Ø600mm	over Ø600mm
Inner diameter	±0,4mm	±0,3mm
Outer diameter	±0,4mm	±0,3mm

Full Face Flanges (FF)																						
Nominal diameter	d1 (mm)	PN6				PN10				PN16				PN25				PN40				
		B.C.D.	d2 (mm)	holes		B.C.D.	d2 (mm)	holes		B.C.D.	d2 (mm)	holes		B.C.D.	d2 (mm)	holes		B.C.D.	d2 (mm)	holes		
				Ø	N			Ø	N			Ø	N			Ø	N			Ø	N	
DN 10	18	50	75	11	4	60	90	14	4	60	90	14	4	60	90	14	4	60	90	14	4	
DN 15	22	55	80	11	4	65	95	14	4	65	95	14	4	65	95	14	4	65	95	14	4	
DN 20	27	65	90	11	4	75	105	14	4	75	105	14	4	75	105	14	4	75	105	14	4	
DN 25	34	75	100	11	4	85	115	14	4	85	115	14	4	85	115	14	4	85	115	14	4	
DN 32	43	90	120	14	4	100	140	18	4	100	140	18	4	100	140	18	4	100	140	18	4	
DN 40	49	100	130	14	4	110	150	18	4	110	150	18	4	110	150	18	4	110	150	18	4	
DN 50	61	110	140	14	4	125	165	18	4	125	165	18	4	125	165	18	4	125	165	18	4	
DN 65	72	130	160	14	4	145	185	18	8	145	185	18	8	145	185	18	8	145	185	18	8	
DN 80	77	150	190	18	4	160	200	18	8	160	200	18	8	160	200	18	8	160	200	18	8	
DN 100	89	170	210	18	4	180	220	18	8	180	220	18	8	190	235	22	8	190	235	22	8	
DN 125	115	200	240	18	8	210	250	18	8	210	250	18	8	220	270	26	8	220	270	26	8	
DN 150	141	225	265	18	8	240	285	22	8	240	285	22	8	250	300	26	8	250	300	26	8	
DN 200	169	280	320	18	8	295	340	22	8	295	340	22	12	310	360	26	12	320	375	30	12	
DN 250	220	335	375	18	12	350	395	22	12	355	405	26	12	370	425	30	12	385	450	33	12	
DN 300	273	395	440	22	12	400	445	22	12	410	460	26	12	430	485	30	16	450	515	33	16	
DN 350	324	445	490	22	12	460	505	22	16	470	520	26	16	490	555	33	16	510	580	36	16	
DN 400	356	495	540	22	16	515	565	26	16	525	580	30	16	550	620	36	16	585	660	39	16	
DN 450	407	550	595	22	16	565	615	26	20	585	640	30	20	600	670	36	20	610	685	39	20	
DN 500	458	600	645	22	20	620	670	26	20	650	715	33	20	660	730	36	20	670	755	42	20	
DN 600	508	705	755	26	20	725	780	30	20	770	840	36	20	770	845	39	20	795	890	48	20	
DN 700	610	810	860	25	24	840	895	30	24	840	910	36	24	875	960	42	24	900	995	48	24	
DN 800	712	920	975	30	24	950	1015	33	24	950	1025	39	24	990	1085	48	24	1030	1140	56	24	
DN 900	813	1020	1075	30	24	1050	1115	33	28	1050	1125	39	28	1090	1185	48	28	1140	1250	56	28	
DN 1000	915	1120	1175	30	28	1160	1230	36	28	1170	1255	42	28	1210	1320	56	28	1250	1360	56	28	
DN 1100	1016	-	-	-	-	1270	1340	39	32	1270	1355	42	32	1310	1420	56	32	-	-	-	-	
DN 1200	1120	1340	1405	33	32	1380	1455	39	32	1390	1485	48	32	1420	1530	56	32	-	-	-	-	
DN 1400	1220	1560	1630	36	36	1590	1675	42	36	1590	1685	48	36	1640	1755	62	36	-	-	-	-	
DN 1500	1420	-	-	-	-	1700	1785	42	36	1710	1820	56	36	1750	1865	62	36	-	-	-	-	
DN 1600	1520	1760	1830	36	40	1820	1915	48	40	1820	1930	56	40	1860	1975	62	40	-	-	-	-	
DN 1800	1620	1970	2045	39	44	2020	2115	48	44	2020	2130	56	44	2070	2195	70	44	-	-	-	-	
DN 2000	1820	2180	2265	42	48	2230	2325	48	48	2230	2345	62	48	2300	2425	70	48	-	-	-	-	
DN 2200	2020	2390	2475	42	52	2440	2550	56	52	-	-	-	-	-	-	-	-	-	-	-	-	
DN 2400	2220	2600	2685	42	56	2650	2760	56	56	-	-	-	-	-	-	-	-	-	-	-	-	
DN 2600	2420	2810	2905	48	60	2850	2960	56	60	-	-	-	-	-	-	-	-	-	-	-	-	
DN 2800	2620	3020	3115	48	64	3070	3180	56	64	-	-	-	-	-	-	-	-	-	-	-	-	
DN 3000	2820	3220	3315	48	68	3290	3405	62	68	-	-	-	-	-	-	-	-	-	-	-	-	
DN 3200	3020	3430	3525	48	72	-	-	-	-	-	-	-	-	-	-	-	-	-	-	-	-	
DN 3400	3220	3640	3735	48	76	-	-	-	-	-	-	-	-	-	-	-	-	-	-	-	-	
DN 3600	3420	3860	3970	56	80	-	-	-	-	-	-	-	-	-	-	-	-	-	-	-	-	
DN 3800	3620	-	-	-	-	-	-	-	-	-	-	-	-	-	-	-	-	-	-	-	-	
DN 4000	3820	-	-	-	-	-	-	-	-	-	-	-	-	-	-	-	-	-	-	-	-	
	4020	-	-	-	-	-	-	-	-	-	-	-	-	-	-	-	-	-	-	-	-	

Spiral wound gaskets

revo seal - Spiral wound CF 4000



REVOSEAL



**SERIES 4000
WITH NO RINGS**



**SERIES 4000
WITH INNER RING**



**SERIES 4000
WITH OUTER RING**



**SERIES 4000 WITH
INNER AND OUTER RING**

Gasket profiles

REVOSEAL

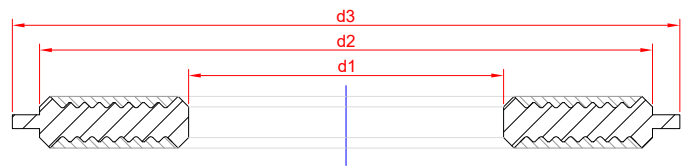
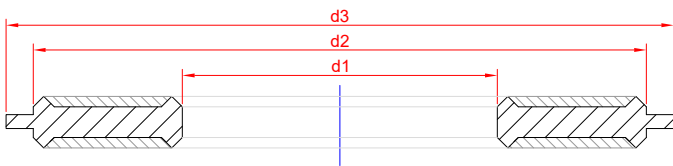
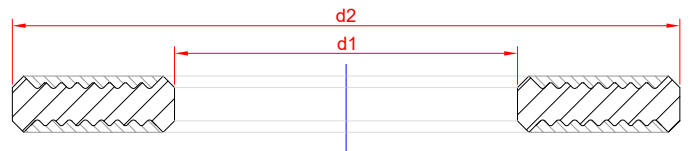
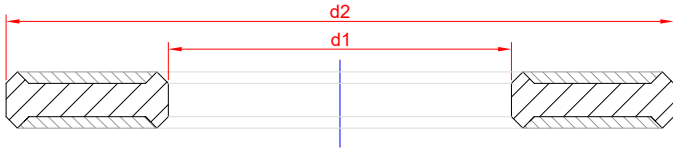

SPIRAL WOUND GASKET WITH RINGS

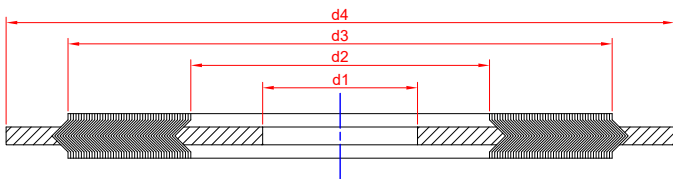

SPIRAL WOUND GASKET WITHOUT RINGS

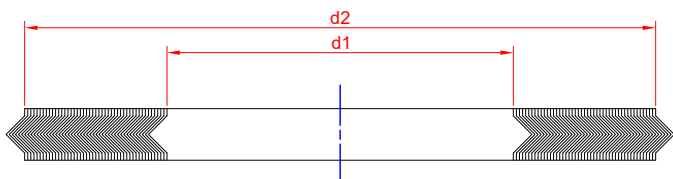

Ring Colour Table for spiral wound Gasket according to Standard ASME B16.20

Material	Abbreviation	Colour code	Example
	Metal part sealing section		
Carbon steel	CRS	Silver	
304 SS	304	Yellow	
304L SS	304 L	No colour	-
309 SS	309	No colour	-
310 SS	310	No colour	-
316L SS	316 L	Green	
317L SS	317 L	Dark Brown	
321 SS	321	Turquoise	
347 SS	347	Blue	
430 SS	430	No colour	-
Titanio	Ti	Purple	
Inconel 600/625	INC 600/INC 625	Gold	
Icoloy 800/825	IN 800/ IN 825	White	-
Inconel X750	INX	No colour	-
Hastelloy C276	HAST C	Beige	
Hastelloy B2	HAST B	Light Brown	
Nickel 200	NI	Red	
Zirconium		No colour	-
Monel 400	MON	Orange	

Material	Abbreviation	Colour code	Example
	Insulating material sealing section		
PTFE	PTFE	White	
Graphite	FG	Grey	
Ceramic	CER	Light Green	
Mica			
Asbestos free	ASB	No colour	///

Marking:

316/graphite spiralwound with inner ring in 316 and outer ring in CS 3"150:
CF 3"150 316/FG/316/CS ASME B16.20

Color:

Green metal part (all band); grey insulation (4 visible strips)

Color to apply to the outer ring:

The colour of the metallic part shall be applied to all measurements for: the whole circumference at the thickness of the centring ring external.
The colour of the insulation up to 1 1/2" must be applied with two visible strips at 180°; from 2" upwards shall be applied with four strips visible at 90°.

Spiral wound gaskets weights table

32C28 (weights in grams)							33C28 (weights in grams)							31C28 (weights in grams)							
DN	150	300	600	900	1500	2500	DN	150	300	400	600	900	1500	2500	DN	150	300	600	900	1500	2500
1/2	31	40	40	62	62	78	1/2	34	45	45	45	63	63	77	1/2	35	49	49	66	66	82
3/4	41	61	61	70	70	87	3/4	47	65	67	67	74	74	89	3/4	49	70	70	78	78	92
1	51	69	69	87	87	106	1	50	80	76	76	95	95	110	1	50	80	76	95	95	110
1 1/4	51	79	79	98	98	155	1 1/4	72	89	88	88	122	122	164	1 1/4	71	89	89	108	108	165
1 1/2	79	100	100	113	113	190	1 1/2	100	120	177	177	132	132	201	1 1/2	85	112	112	130	130	202
2	100	121	121	291	291	293	2	130	155	154	154	293	293	308	2	128	153	153	290	290	310
2 1/2	139	169	169	367	367	387	2 1/2	181	208	208	208	385	385	403	2 1/2	190	210	210	386	386	407
3	115	200	100	304	375	500	3	200	260	267	267	367	403	539	3	195	250	250	360	360	555
4	239	269	269	444	500	682	4	330	350	0,349	450	532	569	757	4	315	340	420	525	525	525
5	200	365	578	635	705	955	5	355	485	0,478	693	744	813	1039	5	335	500	685	742	800	1050
6	220	485	661	882	851	1175	6	400	635	0,619	781	987	965	1312	6	390	615	670	978	941	1325
8	320	630	835	1420	1240	1715	8	520	801	0,838	1000	1493	1418	1846	8	450	760	950	1420	1400	1870
10	445	770	1380	1926	1926	2606	10	722	980	1,055	1573	2135	2135	2757	10	670	890	1300	1880	1930	2600
12	800	975	1695	2669	2764	3363	12	1120	1287	1,346	1900	2708	3082	3591	12	1080	1208	1710	2727	3140	3665
14	1025	1628	1714	2336	3462	-	14	1350	1893	1,912	2069	2790	3831	-	14	1255	1860	1980	2790	4000	-
16	1355	1720	2435	2569	4106	-	16	1730	2177	2,256	2800	3152	4573	-	16	1590	2085	2665	3145	4675	-
18	1030	1887	2465	2985	4638	-	18	1660	2561	2,665	3050	3755	5238	-	18	1340	2350	2840	3640	5290	-
20	1350	2215	3190	3444	5031	-	20	1950	2947	2,993	3766	4300	5709	-	20	1620	2720	3585	4185	5760	-
24	1450	3370	3485	5000	7173	-	24	2500	2919	4,007	4585	5870	7948	-	24	2060	3635	3735	4380	5900	-

Spiral wound Gasket dimensional table according to Standard ASME B16.20

Tolerances	
Spiral thickness (sealing band):	0,127mm
Outer spiral diameter (sealing band):	from 26" to 34" 0,762mm; from 36" to 60" 1,27mm
Internal spiral diameter (sealing band):	from 26" to 60" 1,524mm
Diameter outer centering ring ring:	0,762mm
Thickness of rings (external centering; internal containment):	+0.2 0mm/-0.00mm

Nominal diameter		INNER RING DIAMETER					INSIDE GASKET DIAMETER				
		d1 (mm)					d2 (mm)				
DN	NPS (Inch)	Class 150-300	Class 400-600	Class 900	Class 1500	Class 2500	Class 150-300	Class 400-600	Class 900	Class 1500	Class 2500
15	1/2	14,2	14,2	14,2	14,2	14,2	19,1	19,1	19,1	19,1	19,1
20	3/4	20,6	20,6	20,6	20,6	20,6	25,4	25,4	25,4	25,4	25,4
25	1	26,9	26,9	26,9	26,9	26,9	31,8	31,8	31,8	31,8	31,8
32	1 1/4	38,1	38,1	33,3	33,3	33,3	47,8	47,8	39,6	39,6	39,6
40	1 1/2	44,5	44,5	41,4	41,4	41,4	54,1	54,1	47,8	47,8	47,8
50	2	55,6	55,6	52,3	52,3	52,3	69,9	69,9	58,7	58,7	58,7
65	2 1/2	66,5	66,5	63,5	63,5	63,5	82,6	82,6	69,9	69,9	69,9
80	3	81	81	78,7	78,7	78,7	101,6	101,6	95,3	92,2	92,2
100	4	106,4	102,6	102,6	97,8	97,8	127	120,7	120,7	117,6	117,6
125	5	131,8	128,3	128,3	124,5	124,5	155,7	147,6	147,6	143	143
150	6	157,2	154,9	154,9	147,3	147,3	182,6	174,8	174,8	171,5	171,5
200	8	215,9	205,7	196,9	196,9	196,9	233,4	225,6	222,3	215,9	215,9
250	10	268,2	255,3	246,1	246,1	246,1	287,3	274,6	276,4	266,7	270
300	12	317,5	307,3	292,1	292,1	292,1	339,9	327,2	323,9	323,9	317,5
350	14	349,3	342,9	320,8	320,8	-	371,6	362	355,6	362	-
400	16	400,1	389,9	374,7	368,3	-	422,4	412,8	412,8	406,4	-
450	18	449,3	438,2	425,5	425,5	-	474,7	469,9	463,6	463,6	-
500	20	500,1	489	482,6	476,3	-	525,5	520,7	520,7	514,4	-
600	24	603,3	590,6	590,6	577,9	-	628,7	628,7	628,7	616	-

Nominal diameter		OUTSIDE GASKET DIAMETER		CENTERING RING OUTSIDE DIAMETER						
		d3 (mm)		d4 (mm)						
DN	NPS (Inch)	Class 150-600	Class 900-2500	Class 150	Class 300	Class 400	Class 600	Class 900	Class 1500	Class 2500
15	1/2	31,8	31,8	47,8	54,1	54,1	54,1	63,5	63,5	69,9
20	3/4	39,6	39,6	57,2	66,8	66,8	66,8	69,9	69,9	76,2
25	1	47,8	47,8	66,8	73,2	73,2	73,2	79,5	79,5	85,9
32	1 1/4	60,5	60,5	76,2	82,6	82,6	82,6	88,9	88,9	104,9
40	1 1/2	69,9	69,9	85,9	95,3	95,3	95,3	98,6	98,6	117,6
50	2	85,9	85,9	104,9	111,3	111,3	111,3	143	143	146,1
65	2 1/2	98,6	98,6	124	130,3	130,3	130,3	165,1	165,1	168,4
80	3	120,7	120,7	136,7	149,4	149,4	149,4	168,4	174,8	196,9
100	4	149,4	149,4	174,8	181,1	177,8	193,8	206,5	209,6	235
125	5	177,8	177,8	196,9	215,9	212,9	241,3	247,7	254	279,4
150	6	209,6	209,6	222,3	251	247,7	266,7	289,1	282,7	317,5
200	8	263,7	257,3	279,4	308,1	304,8	320,8	358,9	352,6	387,4
250	10	317,5	311,2	339,9	362	358,9	400,1	435,1	435,1	476,3
300	12	374,7	368,3	409,7	422,4	419,1	457,2	498,6	520,7	549,4
350	14	406,4	400,1	450,9	485,9	482,6	492,3	520,7	577,9	-
400	16	463,6	457,2	514,4	539,8	536,7	565,2	574,8	641,4	-
450	18	527,1	520,7	549,4	596,9	593,9	612,9	638,3	704,9	-
500	20	577,9	571,5	606,6	654,1	647,7	682,8	698,5	755,7	-
600	24	685,8	679,5	717,6	774,7	768,4	790,7	838,2	901,7	-

Spiral wound Gasket dimensional table according to Standard ASME B16.47 Series A (formerly MSS SP44)

Tolerances	
Spiral thickness (sealing band):	0,127mm
Outer spiral diameter (sealing band):	from 26" to 34" 0,762mm; from 36" to 60" 1,27mm
Internal spiral diameter (sealing band):	from 26" to 60" 1,524mm
Diameter outer centering ring ring:	0,762mm
Thickness of rings (external centering; internal containment):	+0.2 0mm/-0.00mm

Nominal diameter	Inner ring diameter					Inside gasket diameter				
	d1 (mm)					d2 (mm)				
	Class 150	Class 300	Class 400	Class 600	Class 900	Class 150	Class 300	Class 400	Class 600	Class 900
26	654,1	654,1	660,4	647,7	660,4	673,1	685,8	685,8	685,8	685,8
28	704,9	704,9	711,2	698,5	711,2	723,9	736,6	736,6	736,6	736,6
30	755,7	755,7	755,7	755,7	768,4	774,7	793,8	793,8	793,8	793,8
32	806,5	806,5	812,8	812,8	812,8	825,5	850,9	850,9	850,9	850,9
34	857,3	857,3	863,6	863,6	863,6	876,3	901,7	901,7	901,7	901,7
36	908,1	908,1	917,7	917,7	920,8	927,1	955,8	955,8	955,8	958,9
38	958,9	952,5	952,5	952,5	1009,7	977,9	977,9	971,6	990,6	1035,1
40	1009,7	1003,3	1000,3	1009,7	1060,5	1028,7	1022,4	1025,7	1047,8	1098,6
42	1060,5	1054,1	1051,1	1066,8	1111,3	1079,5	1073,2	1076,5	1104,9	1149,4
44	1111,3	1104,9	1104,9	1111,3	1219,2	1130,3	1130,3	1130,3	1162,1	1206,5
46	1162,1	1152,7	1168,4	1162,1	1270	1181,1	1178,1	1193,8	1212,9	1270
48	1212,9	1209,8	1206,5	1219,2	-	1231,9	1235,2	1244,6	1270	1320,8
50	1263,7	1244,6	1257,3	1270	-	1282,7	1295,4	1295,4	1320,8	-
52	1314,5	1320,8	1308,1	1320,8	-	1333,5	1346,2	1346,2	1371,6	-
54	1358,9	1352,6	1352,6	1378	-	1384,3	1403,4	1403,4	1428,8	-
56	1409,7	1403,4	1403,4	1428,8	-	1435,1	1454,2	1454,2	1479,6	-
58	1460,5	1447,8	1454,2	1473,2	-	1485,9	1511,3	1505	1536,7	-
60	1511,3	1524	1517,7	1530,4	-	1536,7	1562,1	1568,5	1593,9	-

Nominal diameter	Outside gasket diameter					Centering ring outside diameter				
	d3 (mm)					d4 (mm)				
	Class 150	Class 300	Class 400	Class 600	Class 900	Class 150	Class 300	Class 400	Class 600	Class 900
26	704,9	736,6	736,6	736,6	736,6	774,7	835,2	831,9	866,9	882,7
28	755,7	787,4	787,4	787,4	787,4	831,9	898,7	892,3	914,4	946,2
30	806,5	844,6	844,6	844,6	844,6	882,7	952,5	946,2	971,6	1009,7
32	860,6	901,7	901,7	901,7	901,7	939,8	1006,6	1003,3	1022,4	1073,2
34	911,4	952,5	952,5	952,5	952,5	990,6	1057,4	1054,1	1073,2	1136,7
36	968,5	1006,6	1006,6	1006,6	1009,7	1047,8	1117,6	1117,6	1130,3	1200,2
38	1019,3	1016	1022,4	1041,4	1085,9	1111,3	1054,1	1073,2	1104,9	1200,2
40	1070,1	1070,1	1076,5	1098,6	1149,4	1162,1	1114,6	1127,3	1155,7	1251
42	1124	1120,9	1127,3	1155,7	1200,2	1219,2	1165,4	1178,1	1219,2	1301,8
44	1178,1	1181,1	1181,1	1212,9	1257,3	1276,4	1219,2	1231,9	1270	1368,6
46	1228,9	1228,9	1244,6	1263,7	1320,8	1327,2	1273,3	1289,1	1327,2	1435,1
48	1279,7	1286	1295,4	1320,8	1371,6	1384,3	1324,1	1346,2	1390,7	1485,9
50	1333,5	1346,2	1346,2	1371,6	-	1435,1	1378	1403,4	1447,8	-
52	1384,3	1397	1397	1422,4	-	1492,3	1428,8	1454,2	1498,6	-
54	1435,1	1454,2	1454,2	1479,6	-	1549,4	1492,3	1517,7	1555,8	-
56	1485,9	1505	1505	1530,4	-	1606,6	1543,1	1568,5	1612,9	-
58	1536,7	1562	1555,8	1587,5	-	1663,7	1593,9	1619,3	1663,7	-
60	1587,5	1612,9	1619,3	1644,7	-	1714,5	1644,7	1682,8	1733,6	-

Spiral wound Gasket dimensional table according to Standard ASME B16.47 Series B (formerly API 605)

Tolerances	
Spiral thickness (sealing band):	0,127mm
Outer spiral diameter (sealing band):	from 26" to 34" 0,762mm; from 36" to 60" 1,27mm
Internal spiral diameter (sealing band):	from 26" to 60" 1,524mm
Diameter outer centering ring ring:	0,762mm
Thickness of rings (external centering; internal containment):	+0.2 0mm/-0.00mm

Nominal diameter	Inner ring diameter					Inside gasket diameter				
	d1 (mm)					d2 (mm)				
	Class 150	Class 300	Class 400	Class 600	Class 900	Class 150	Class 300	Class 400	Class 600	Class 900
26	654,1	654,1	654,1	644,7	666,8	673,1	673,1	666,8	663,7	692,2
28	704,9	704,9	701,8	685,8	717,6	723,9	723,9	714,5	704,9	743
30	755,7	755,7	752,6	752,6	781,1	774,7	774,7	765,3	778	806,5
32	806,5	806,5	800,1	793,8	838,2	825,5	825,5	812,8	831,9	863,6
34	857,3	857,3	850,9	850,9	895,4	876,3	876,3	866,9	889	920,8
36	908,1	908,1	898,7	901,7	920,8	927,1	927,1	917,7	939,8	946,2
38	958,9	971,6	952,5	952,5	1009,7	974,9	1009,7	971,6	990,6	1035,1
40	1009,7	1022,4	1000,3	1009,7	1060,5	1022,4	1060,5	1025,7	1047,8	1098,6
42	1060,5	1085,9	1051,1	1066,8	1111,3	1079,5	1111,3	1079,5	1104,9	1149,4
44	1111,3	1124	1104,9	1111,3	1155,7	1124	1162,1	1130,3	1162,1	1206,5
46	1162,1	1178,1	1168,4	1162,1	1219,2	1181,1	1216,2	1193,8	1212,9	1270
48	1212,9	1231,9	1206,5	1219,2	1270	1231,9	1263,7	1244,6	1270	1320,8
50	1263,7	1267	1257,3	1270	-	1282,7	1317,8	1295,4	1320,8	-
52	1314,5	1317,8	1308,1	1320,8	-	1333,5	1368,6	1346,2	1371,6	-
54	1365,3	1365,3	1352,6	1378	-	1384,3	1403,4	1403,4	1428,8	-
56	1422,4	1428,8	1403,4	1428,8	-	1444,8	1479,6	1454,2	1479,6	-
58	1478	1484,4	1454,2	1473,2	-	1500,1	1535,2	1505	1536,7	-
60	1535,2	1557,3	1517,7	1530,4	-	1557,3	1589	1568,5	1593,9	-

Nominal diameter	Outside gasket diameter					Centering ring outside diameter				
	d3 (mm)					d4 (mm)				
	Class 150	Class 300	Class 400	Class 600	Class 900	Class 150	Class 300	Class 400	Class 600	Class 900
26	698,5	711,2	698,5	714,5	749,3	725,4	771,7	746,3	765,3	838,2
28	749,3	762	749,3	755,7	800,1	776,2	825,5	800,1	819,2	901,7
30	800,1	812,8	806,5	828,8	857,3	827	886	857,3	879,6	958,9
32	850,9	863,6	860,6	882,7	914,4	881,1	939,8	911,4	933,5	1016
34	908,1	914,4	911,4	939,8	971,6	935	993,9	962,2	997	1073,2
36	958,9	965,2	965,2	990,6	997	987,6	1047,8	1022,4	1047,8	1124
38	1009,7	1047,8	1022,4	1041,4	1085,9	1044,7	1098,6	1073,2	1104,9	1200,2
40	1063,8	1098,6	1076,5	1098,6	1149,4	1095,5	1149,4	1127,3	1155,7	1251
42	1114,6	1149,4	1127,3	1155,7	1200,2	1146,3	1200,2	1178,1	1219,2	1301,8
44	1165,4	1200,2	1181,1	1212,9	1257,3	1197,1	1251	1231,9	1270	1368,6
46	1224	1254,3	1244,6	1263,7	1320,8	1255,8	1317,8	1289,1	1327,2	1435,1
48	1270	1311,4	1295,4	1320,8	1371,6	1306,6	1368,6	1346,2	1390,7	1485,9
50	1325,6	1355,9	1346,2	1371,6	-	1357,4	1419,4	1403,4	1447,8	-
52	1376,4	1406,7	1397	1422,4	-	1408,2	1470,2	1454,2	1498,6	-
54	1422,4	1454,2	1454,2	1479,6	-	1463,8	1530,4	1517,7	1555,8	-
56	1478	1524	1505	1530,4	-	1514,6	1593,9	1568,5	1612,9	-
58	1528,8	1573,3	1555,8	1587,5	-	1579,6	1655,8	1619,3	1663,7	-
60	1586	1630,4	1619,3	1644,7	-	1630,4	1706,6	1682,8	1733,6	-

Spiral wound Gasket dimensional table according to Standard ASME B16.20

Tolerances

Spiral thickness (sealing band):	0,127mm
from 1/2" to 6"	Øint ±0,4; Øext ±0,8
from 8" to 14"	Øint ±0,8; Øext +1,5/-0,8
from 16" to 24"	Øint ±0,8; Øext ±1,5

Nominal diameter	LTG		LMF		STG	
	Large Tongue/Groove		Large Male & Female		Small Tongue/Groove	
	d1 (mm)	d2 (mm)	d1 (mm)	d2 (mm)	d1 (mm)	d2 (mm)
1/2	25,4	34,9	21,4	34,9	25,4	34,9
3/4	33,3	42,9	27	42,9	33,3	42,9
1	38,1	50,8	33,3	50,8	38,1	47,6
1 1/4	47,6	63,5	42	63,5	47,6	57,5
1 1/2	54	73	48,4	73	54	63,5
2	73	92	60,3	92	73	82,5
2 1/2	85,7	104,8	73	104,8	85,7	95,2
3	107,9	127	88,9	127	107,9	117,5
3 1/2	120,6	139,7	101,6	139,7	120,6	130,2
4	131,8	157	114,3	157,2	131,8	144,5
5	160,3	185,7	141,3	185,7	160,3	173
6	190,5	215,9	168,3	215,9	190,5	203,2
8	238,1	269,9	219,1	269,9	238,1	254
10	285,7	323,8	273	323,8	285,7	304,8
12	342,9	381	323,8	381	342,9	361,9
14	374,6	412,7	355,6	412,7	374,6	393,7
16	425,4	469,9	406,4	469,9	425,4	447,7
18	488,9	533,4	457,2	533,4	488,9	511,2
20	533,4	584,2	50,8	584,2	533,4	558,8
24	641,3	692,1	609	692,1	641,3	666,7

Spiral wound Gasket dimensional table according to Standard EN1514-2

Tolerances	
Spiral thickness (sealing band):	0,127mm
Outer spiral diameter (sealing band):	from DN10 to DN200 $\pm 0,406$ mm; from DN250 to DN900 $+1,524$ mm/ $-0,762$ mm
Internal spiral diameter (sealing band):	from DN10 to DN200 $\pm 0,406$ mm; from DN250 to DN900 $\pm 0,762$ mm
Diameter outer centering ring:	0,762mm
Thickness of rings (external centering; internal containment):	$+0.20$ mm/ -0.00 mm

Nominal diameter	Inner ring diameter	Inside gasket diameter	Outside gasket diameter		Centering ring outside diameter							
	d1 (mm)	d2 (mm)	d3 (mm)		d4 (mm)							
	PN10/320	PN10/320	PN10/40	PN63/320	PN10	PN25	PN40	PN63	PN100	PN160	PN250	PN320
10	18	24	34	34	45	45	45	56	56	56	67	67
15	23	29	39	-	51	51	51	61	61	61	72	72
20	28	34	46	46	61	61	61	-	-	-	77	77
25	35	41	53	53	71	71	71	82	82	82	83	92
32	43	49	61	-	82	82	82	-	-	-	100	-
40	50	56	68	68	92	92	92	103	103	103	109	119
50	61	70	86	86	107	107	107	113	119	119	124	134
65	77	86	102	106	127	127	127	137	143	143	153	170
80	90	99	115	119	142	142	142	148	154	154	170	190
100	115	127	143	147	162	168	168	174	180	180	202	229
125	140	152	172	176	192	194	194	210	217	217	242	274
150	167	179	199	203	217	224	224	247	257	257	284	311
200	216	228	248	252	272	284	290	309	324	324	358	398
250	267	279	303	307	327	340	352	364	391	388	442	488
300	318	330	354	358	377	400	417	424	458	458	538	-
350	360	376	400	404	437	457	474	486	512	-	-	-
400	410	422	450	456	488	514	546	543	572	-	-	-
500	510	522	550	556	593	624	628	657	704	-	-	-
600	610	622	650	656	695	731	747	764	813	-	-	-
700	710	722	756	762	810	833	852	879	950	-	-	-
800	810	830	864	870	917	942	974	988	-	-	-	-
900	910	930	964	970	1017	1042	1084	1108	-	-	-	-
1000	1010	1030	1074	1080	1124	1154	1194	-	-	-	-	-

Spiral wound Gasket dimensional table according to Standard DIN 2691/ 2692

Tolerances	
Spiral thickness (sealing band)	0,127mm
from DN15 to DN200	Øint ±0,4; Øext ±0,8
from DN250 to DN600	Øint ±0,8; Øext +1,5/-0,8
from DN700 to DN1000	Øint ±0,8; Øext ±1,5

Large Tongue and Groove
Large Male & Female
Small Tongue and Groove

Nominal diameter	LTG/STG (DIN 2691)		LMF (DIN 2692)	
	Large Tongue/Groove		Large Male & Female	
	d1 (mm)	d2 (mm)	d1 (mm)	d2 (mm)
DN6	20	30	8	30
DN8	22	32	10	32
DN 10	24	34	18	34
DN 15	29	39	22	39
DN 20	36	50	28	50
DN 25	43	57	35	57
DN 32	51	65	43	65
DN 40	61	75	49	75
DN 50	73	87	61	87
DN 65	95	109	77	109
DN 80	106	120	90	120
DN 100	129	149	115	149
DN 125	155	175	141	175
DN 150	183	203	169	203
DN 175	213	233	195	233
DN 200	239	259	220	259
DN 250	292	312	274	312
DN 300	343	363	325	363
DN 350	395	421	368	421
DN 400	447	473	420	473
DN 500	549	575	520	575
DN 600	649	675	620	675
DN 700	751	777	720	777
DN 800	856	882	820	882
DN 900	961	987	920	987
DN 1000	1062	1092	1020	1091

Metal jacketed gaskets

Metal jacketed CF 5000



SERIES 5000

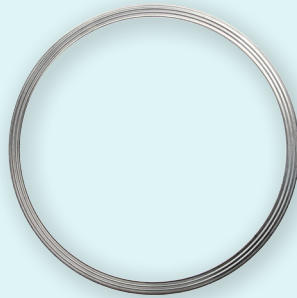

SERIES 5003



SERIES 5035

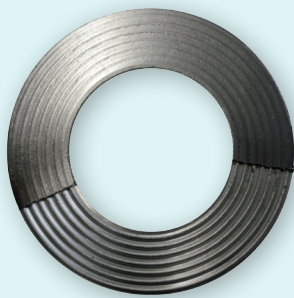

SERIES 5060

Metal Jacketed Gasket dimensional table according to Standard ASME B16.20

Notes

The standard thickness of the metaljacketed is 3mm

Tolerances

Up to 24" Øint +0,4mm/0,0mm

Up to 24" Øext +0,0mm/-0,4mm

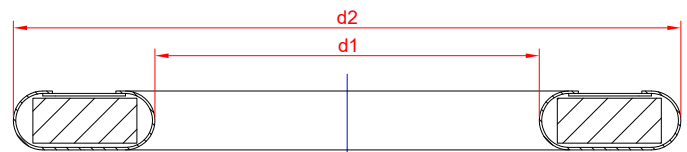

Nominal diameter	d1 (mm)	d2 (mm)						
		Class 150	Class 300	Class 400	Class 600	Class 900	Class 1500	Class 2500
1/2	23,8	44,5	50,8	50,8	50,8	60,4	60,4	66,8
3/4	31,8	54	63,5	63,5	63,5	66,7	66,7	73,1
1	36,5	63,5	69,9	69,9	69,9	76,2	76,2	82,5
1 1/4	46	73	79,4	79,4	79,4	85,8	85,8	101,6
1 1/2	52,4	82,6	92,1	92,1	92,1	95,3	95,3	114,3
2	73,2	101,6	108	108	108	139,7	139,7	143
2 1/2	85,9	120,6	127	127	127	161,9	161,9	165,1
3	107,8	133,4	146,1	146,1	146,1	165,1	171,5	193,8
4	131,8	171,5	177,8	174,7	190,5	203,2	206,5	231,9
5	152,4	193,8	212,8	209,5	238,2	244,6	250,9	276,3
6	190,5	219,1	247,7	244,5	263,6	285,8	279,4	314,5
8	238,3	276,3	304,8	301,7	317,5	355,6	349,3	384,3
10	285,8	336,6	358,8	355,6	396,9	431,8	431,8	473,2
12	342,9	406,4	419,1	415,9	454,1	495,3	517,6	546,1
14	374,7	447,7	482,6	479,5	489	517,6	574,7	-
16	425,5	511,2	536,6	533,4	562	571,5	638,2	-
18	489	546,1	593,7	590,6	609,6	635	701,8	-
20	533,4	603,3	650,9	644,5	679,5	695,5	752,5	-
24	641,4	714,4	771,6	765,3	787,4	835,1	898,6	-

Metal Jacketed Gasket dimensional table according to Standard EN1514-4

Notes

The standard thickness of the metaljacketed is 3mm

Tolerances

Up to 24" Øint +0,4mm/0,0mm

Up to 24" Øext +0,0mm/-0,4mm

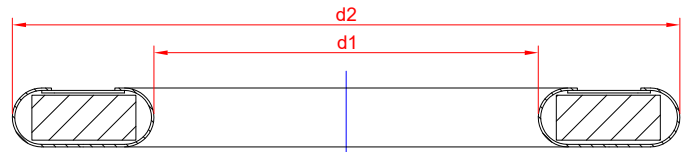

Nominal diameter	d1	d2					
		PN10	PN16	PN25	PN40	PN63	PN100
DN10	18	48	48	48	48	58	58
DN15	22	53	53	53	53	63	63
DN20	27	63	63	63	63	74	74
DN25	34	73	73	73	73	84	84
DN32	43	84	84	84	84	90	90
DN40	49	94	94	94	94	105	105
DN50	61	109	109	109	109	115	121
DN65	77	129	129	129	129	140	146
DN80	89	144	144	144	144	150	156
DN100	115	164	164	170	170	176	183
DN125	141	194	194	196	196	213	220
DN150	169	220	220	226	226	250	260
DN200	220	275	275	286	293	312	327
DN250	273	330	331	343	355	367	394
DN300	324	380	386	403	420	427	461
DN350	356	440	446	460	477	489	515
DN400	407	491	498	517	549	546	575
DN450	458	541	558	567	574	-	-
DN500	508	596	620	627	631	660	708
DN600	610	698	737	734	750	768	819
DN700	712	813	807	836	-	883	956
DN800	813	920	914	945	-	994	-
DN900	915	1020	1014	1045	-	1114	-

Camprofile gaskets

revo seal - Camprofile CF 6000



REVOSEAL

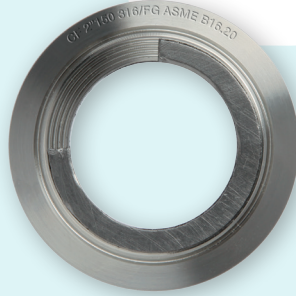

SERIES 6000

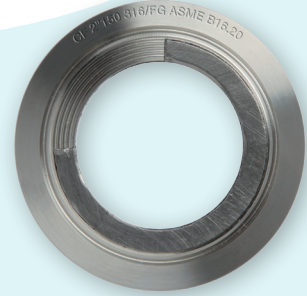

**CF6000 METALGROOVED
WITH EXTERNAL ONE
PIECE RING**

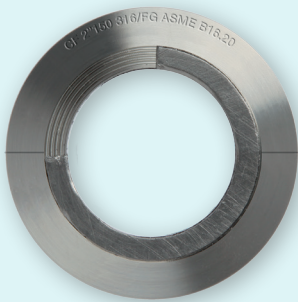

**CF6000 METALGROOVED
WITH FLOATING RING**



**CF6000 METALGROOVED
CONVEX PROFILE**

Gasket profiles

REVOSEAL

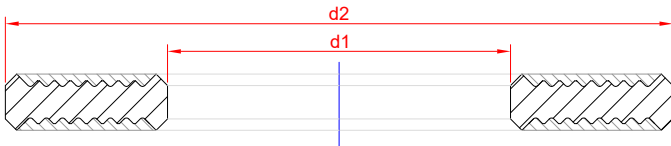
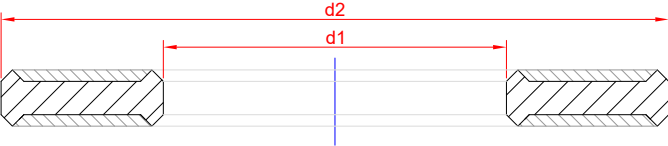

CAMPROFILE FLOATING RING



CAMPROFILE WITH INTEGRAL RING



CAMPROFILE WITHOUT RING

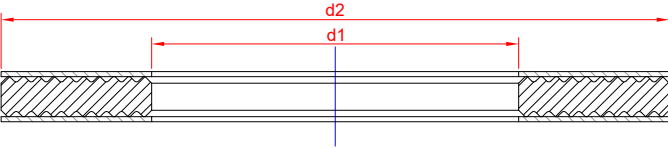

Camprofile Gasket dimensional table according to Standard ASME B16.20

Notes

The standard thickness of the inner core is 4mm

The thickness of graphite layers (or ptfe) is 0.5mm

The centering ring ring (if required) can be one-piece or floating

Tolerances

Øint +0,4mm/0,0mm

Øext +0,0mm/-0,4mm

Nominal diameter	d1 (mm)	d2 (mm)	d3 (mm)						
			Class 150	Class 300	Class 400	Class 600	Class 900	Class 1500	Class 2500
1/2	23,1	33,3	47,8	54,1	54,1	54,1	63,5	63,5	69,9
3/4	28,7	39,6	57,2	66,8	66,8	66,8	69,9	69,9	76,2
1	36,6	47,5	66,8	73,2	73,2	73,2	79,5	79,5	85,9
1 1/4	44,5	60,2	76,2	82,6	82,6	82,6	88,9	88,9	104,9
1 1/2	52,3	69,9	85,9	95,3	95,3	95,3	98,6	98,6	117,6
2	69,9	88,9	104,9	111,3	111,3	111,3	143	143	146,1
2 1/2	82,6	101,6	124	130,3	130,3	130,3	165,1	165,1	168,4
3	98,3	123,7	136,7	149,4	149,4	149,4	168,4	174,8	196,9
3 1/2	111,1	136,5	158,8	161,9	158,7	158,7	-	-	-
4	123,7	153,9	174,8	181,1	177,8	193,8	206,5	209,6	235
5	150,9	182,6	196,9	215,9	212,9	241,3	247,7	254	279,4
6	177,8	212,6	222,3	251	247,7	266,7	289,1	282,7	317,5
8	228,6	266,7	279,4	308,1	304,8	320,8	358,9	352,6	387,4
10	282,7	320,8	339,9	362	358,9	400,1	435,1	435,1	476,3
12	339,6	377,7	409,7	422,4	419,1	457,2	498,6	520,7	549,4
14	371,6	409,7	450,9	485,9	482,6	492,3	520,7	577,9	-
16	422,4	466,6	514,4	539,8	536,7	565,2	574,8	641,4	-
18	479,3	530,1	549,4	596,9	593,9	612,9	638,3	704,9	-
20	530,1	580,9	606,6	654,1	647,7	682,8	698,5	755,7	-
22	581	631,8	657,2	701,7	698,5	730,3	-	-	-
24	631,7	682,5	717,6	774,7	768,4	790,7	838,2	901,7	-

Camprofile Gasket dimensional table according to Standard ASME B16.47 Series A (before MSS-SP44)

Notes

The standard thickness of the inner core is 4mm

The thickness of graphite layers (or ptfe) is 0.5mm

The centering ring ring (if required) can be one-piece or floating

Tolerances

Øint +0,4mm/0,0mm

Øext +0,0mm/-0,4mm

Nominal diameter	d1 (mm)	d2 (mm)	d3 (mm)	d1 (mm)	d2 (mm)	d3 (mm)	d1 (mm)	d2 (mm)	d3 (mm)
	Class 150			Class 300			Class 400		
26	673,1	704,9	774,7	685,8	736,6	835,2	685,8	736,6	831,9
28	723,9	755,7	831,9	736,6	787,4	898,7	736,6	787,4	892,3
30	774,7	806,5	882,7	793,8	844,6	952,5	793,8	844,6	946,2
32	825,5	860,6	939,8	850,9	901,7	1006,6	850,9	901,7	1003,3
34	876,3	911,4	990,6	901,7	952,5	1057,4	901,7	952,5	1054,1
36	927,1	968,5	1047,8	955,8	1006,6	1117,6	955,8	1006,6	1117,6
38	977,9	1019,3	1111,3	977,9	1016,0	1054,1	971,6	1022,4	1073,2
40	1028,7	1070,1	1162,1	1022,4	1070,1	1114,6	1025,7	1076,5	1127,3
42	1079,5	1124,0	1219,2	1073,2	1120,9	1165,4	1076,5	1127,3	1178,1
44	1130,3	1178,1	1276,4	1130,3	1181,1	1219,2	1130,3	1181,1	1231,9
46	1181,1	1228,9	1327,2	1178,1	1228,9	1273,3	1193,8	1244,6	1289,1
48	1231,9	1279,7	1384,3	1235,2	1286,0	1324,1	1244,6	1295,4	1346,2
50	1282,7	1333,5	1435,1	1295,4	1346,2	1378,0	1295,4	1346,2	1403,4
52	1333,5	1384,3	1492,3	1346,2	1397,0	1428,8	1346,2	1397,0	1454,2
54	1384,3	1435,1	1549,4	1403,4	1454,2	1492,3	1403,4	1454,2	1517,7
56	1435,1	1485,9	1606,6	1454,2	1505,0	1543,1	1454,2	1505,0	1568,5
58	1485,9	1536,7	1663,7	1511,3	1562,1	1593,9	1505,0	1555,8	1619,3
60	1536,7	1587,5	1714,5	1562,1	1612,9	1644,7	1568,5	1619,3	1682,8

Nominal diameter	d1 (mm)	d2 (mm)	d3 (mm)	d1 (mm)	d2 (mm)	d3 (mm)
	Class 600			Class 900		
26	685,8	736,6	866,9	685,8	736,6	882,7
28	736,6	787,4	914,4	736,6	787,4	946,2
30	793,8	844,6	971,6	793,8	844,6	1009,7
32	850,9	901,7	1022,4	850,9	901,7	1073,2
34	901,7	952,5	1073,2	901,7	952,5	1136,7
36	955,8	1006,6	1130,3	958,9	1009,7	1200,2
38	990,6	1041,4	1104,9	1035,1	1085,9	1200,2
40	1047,8	1098,6	1155,7	1098,6	1149,4	1251,0
42	1104,9	1155,7	1219,2	1149,4	1200,2	1301,8
44	1162,1	1212,9	1270,0	1206,5	1257,3	1369,6
46	1212,9	1263,7	1327,2	1270,0	1320,8	1435,1
48	1270,0	1320,8	1390,7	1320,8	1371,6	1485,9
50	1320,8	1371,6	1447,8	-	-	-
52	1371,6	1422,4	1498,6	-	-	-
54	1428,8	1479,6	1555,8	-	-	-
56	1479,6	1530,4	1612,9	-	-	-
58	1536,7	1587,5	1663,7	-	-	-
60	1593,9	1644,7	1733,6	-	-	-

Camprofile Gasket dimensional table according to Standard ASME B16.47 Series B (before MSS-SP44)

Notes

The standard thickness of the inner core is 4mm

The thickness of graphite layers (or ptfe) is 0.5mm

The centering ring ring (if required) can be one-piece or floating

Tolerances

Øint +0,4mm/0,0mm

Øext +0,0mm/-0,4mm

Nominal diameter	d1 (mm)	d2 (mm)	d3 (mm)	d1 (mm)	d2 (mm)	d3 (mm)	d1 (mm)	d2 (mm)	d3 (mm)
	Class 150			Class 300			Class 400		
26	673,1	698,5	725,4	673,1	711,2	771,7	666,8	698,5	746,3
28	723,9	749,3	776,2	723,9	762,0	825,5	714,5	749,3	800,1
30	774,7	800,1	827,0	774,7	812,8	886,0	765,3	806,5	857,3
32	825,5	850,9	881,1	825,5	863,6	939,8	812,8	860,6	911,4
34	876,3	908,1	935,0	876,3	914,4	993,9	866,9	911,4	962,2
36	927,1	958,9	987,6	927,1	965,2	1047,8	917,7	965,2	1022,4
38	974,9	1009,7	1044,7	1009,7	1047,8	1098,6	971,6	1022,4	1073,2
40	1022,4	1063,8	1095,5	1060,5	1098,6	1149,4	1025,7	1076,5	1127,3
42	1079,5	1114,6	1146,3	1111,3	1149,4	1200,2	1076,5	1127,3	1178,1
44	1124,0	1165,4	1197,1	1162,1	1200,2	1251,0	1130,3	1181,1	1231,9
46	1181,1	1224,0	1255,8	1216,2	1254,3	1317,8	1193,8	1244,6	1289,1
48	1231,9	1270,0	1306,6	1263,7	1311,4	1368,6	1244,6	1295,4	1346,2
50	1282,7	1325,6	1357,4	1317,8	1355,9	1419,4	1295,4	1346,2	1403,4
52	1333,5	1376,4	1408,2	1368,6	1406,7	1470,2	1346,2	1397,0	1454,2
54	1384,3	1422,4	1463,8	1403,4	1454,2	1530,4	1403,4	1454,2	1517,7
56	1444,8	1478,0	1514,6	1479,6	1524,0	1593,9	1454,2	1505,0	1568,5
58	1500,6	1528,8	1579,6	1535,2	1573,3	1655,8	1505,0	1555,8	1619,3
60	1557,3	1586,0	1630,4	1589,0	1630,4	1706,6	1568,5	1619,3	1682,8

Nominal diameter	d1 (mm)	d2 (mm)	d3 (mm)	d1 (mm)	d2 (mm)	d3 (mm)
	Class 600			Class 900		
26	663,7	714,5	765,3	692,2	749,3	838,2
28	704,9	755,7	819,2	743,0	800,1	901,7
30	778,0	828,8	879,6	806,5	857,3	958,9
32	831,9	882,7	933,5	863,9	914,4	1016,0
34	889,0	939,8	997,0	920,8	971,6	1073,2
36	939,8	990,6	1047,8	946,2	997,0	1124,0
38	990,6	1041,4	1104,9	1035,1	1085,9	1200,2
40	1047,8	1098,6	1155,7	1098,6	1149,4	1251,0
42	1104,9	1155,7	1219,2	1149,4	1200,2	1301,8
44	1162,1	1212,9	1270,0	1206,5	1257,3	1368,6
46	1212,9	1263,7	1327,2	1270,0	1320,8	1435,1
48	1270,0	1320,8	1390,7	1320,8	1371,6	1485,9
50	1320,8	1371,6	1447,8	-	-	-
52	1371,6	1422,4	1498,6	-	-	-
54	1428,8	1479,6	1555,8	-	-	-
56	1479,6	1530,4	1612,9	-	-	-
58	1536,7	1587,5	1663,7	-	-	-
60	1593,9	1644,7	1733,6	-	-	-

Camprofile Gasket dimensional table according to Standard EN 1514-6

Notes

The standard thickness of the inner core is 4mm

The thickness of graphite layers (or ptfe) is 0.5mm

The centering ring ring (if required) can be one-piece or floating

Tolerances

Up to DN1000 $\varnothing_{int} +0,4mm/0,0mm$ Above DN1000 $\varnothing_{int} +1,0mm/-0,0mm$

Up to DN1000 $\varnothing_{ext} +0,0mm/-0,4mm$ Above DN1000 $\varnothing_{ext} +0,0mm/-1,0mm$

Nominal diameter	d1 (mm)	d2 (mm)			d2 (mm)									
		PN1040	PN63-160	PN250-400	PN10	PN16	PN25	PN40	PN64	PN100	PN160	PN250	PN320	PN400
DN10	22	36	36	36	46	46	46	46	56	56	56	67	67	67
DN15	26	42	42	42	51	51	51	51	61	61	61	72	72	-
DN20	31	47	47	47	61	61	61	61	-	-	-	-	-	-
DN25	36	52	52	52	71	71	71	71	82	82	82	83	92	104
DN32	46	62	62	66	82	82	82	82	-	-	-	-	-	-
DN40	53	69	69	73	92	92	92	92	103	103	103	109	119	135
DN50	65	81	81	87	107	107	107	107	113	119	119	124	134	150
DN65	81	100	100	103	127	127	127	127	137	143	143	153	170	192
DN80	95	115	115	121	142	142	142	142	148	154	154	170	190	207
DN100	118	138	138	146	162	162	168	168	174	180	180	202	229	256
DN125	142	162	162	178	192	192	194	194	210	217	217	242	274	301
DN150	170	190	190	212	217	217	224	224	247	257	257	284	311	348
DN175	195	215	215	245	247	247	254	265	277	287	284	316	358	402
DN200	220	240	248	280	272	272	284	290	309	324	324	358	398	442
DN250	270	290	300	340	327	328	340	352	364	391	388	442	488	-
DN300	320	340	356	400	377	383	400	417	424	458	458	536	-	-
DN350	375	395	415	-	437	443	457	474	486	512	-	-	-	-
DN400	426	450	474	-	489	495	514	546	543	572	-	-	-	-
DN450	480	506	-	-	539	555	-	571	-	-	-	-	-	-
DN500	530	560	588	-	594	617	624	628	657	704	-	-	-	-
DN600	630	664	700	-	695	734	731	747	764	813	-	-	-	-
DN700	730	770	812	-	810	804	833	852	879	950	-	-	-	-
DN800	830	876	886	-	917	911	942	974	988	-	-	-	-	-
DN900	930	982	994	-	1017	1011	1042	1084	1108	-	-	-	-	-
DN1000	1040	1098	1110	-	1124	1128	1154	1194	1220	-	-	-	-	-
DN1200	1250	1320	1334	-	1341	1342	1364	1398	1452	-	-	-	-	-
DN1400	1440	1522	-	-	1548	1542	1578	1618	-	-	-	-	-	-
DN1600	1650	1742	-	-	1772	1764	1798	1830	-	-	-	-	-	-
DN1800	1850	1914	-	-	1972	1964	2000	-	-	-	-	-	-	-
DN2000	2050	2120	-	-	2182	2168	2230	-	-	-	-	-	-	-
DN2200	2250	2328	-	-	2384	2378	-	-	-	-	-	-	-	-
DN2400	2460	2512	-	-	2594	-	-	-	-	-	-	-	-	-
DN2600	2670	2728	-	-	2794	-	-	-	-	-	-	-	-	-
DN2800	2890	2952	-	-	3014	-	-	-	-	-	-	-	-	-
DN3000	3100	3166	-	-	3228	-	-	-	-	-	-	-	-	-

Ring Joint

Ring Joint CF 7000



**SERIES 7000
TYPE R OVAL**

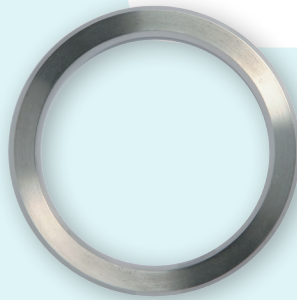

**SERIES 7000
TYPE R OCTAGONAL**

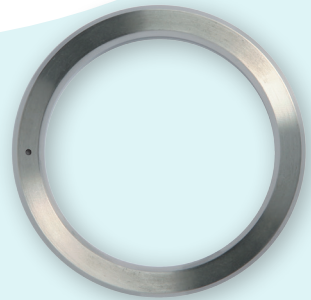

**SERIES 7000
BX**

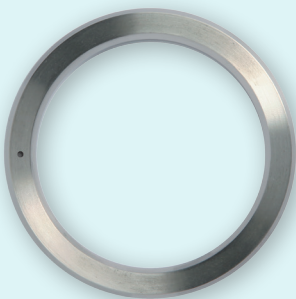

**SERIES 7000
RX**

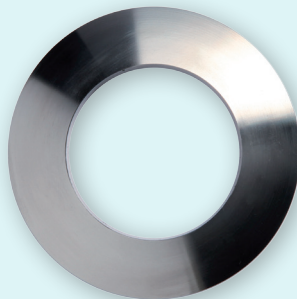

**SERIES 7000
LENS GASKETS**

Ring Joint gasket material hardness table according to Standard ASME B16.20

Material	Material	Maximum Hardness	Maximum Hardness	Material code
ASTM	DIN	Brinell (HB)	Rockwell B	ASME
Soft Iron	1,1003	90	56	D
Carbon Steel	1,0038	120	68	S
AISI 502	1,7362	130	72	F5
AISI 410	1,4000	170	86	S410
AISI 304	1,4301	160	83	S304
AISI 316	1,4401	160	83	S316
AISI 347	1,445	160	83	S347
Monel 400	2,4368	125	83	M
Nickel 200	2,4660	110	58	N
Rame	2,0090	120	68	CU
Alluminio	-	35	-	Al
Hastelloy B2	2,4617	230	121	X1
Hastelloy C276	2,4819	210	110	X2
Inconel 600	2,4816	150	78	Y
Incoloy 825	2,4858	150	78	Y

Type R Ring Joint gasket dimensional table according to standard ASME B16.47 Series A and API 6B

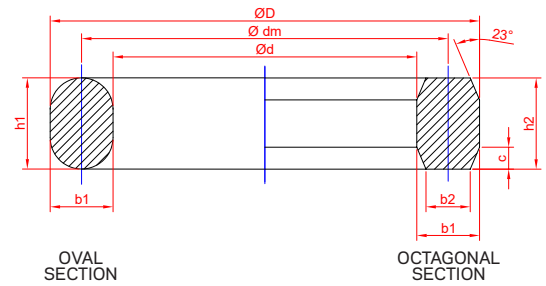

Type R	Nominal diameter with DN (inch)									
	ASME/ANSI B16.5					ASME B16.47A		API 6B		
	Class 150	Class 300/600	Class 900	Class 1500	Class 2500	Class 300/600	Class 900	Class 2000	Class 3000	Class 5000
R11		1/2								
R12			1/2	1/2						
R13		3/4			1/2					
R14			3/4	3/4						
R15	1									
R16		1	1	1	3/4			1	1	1
R17	1 1/4									
R18		1 1/4	1 1/4	1 1/4	1			1 1/4	1 1/4	1 1/4
R19	1 1/2									
R20		1 1/2	1 1/2	1 1/2				1 1/2	1 1/2	1 1/2
R21					1 1/4					
R22	2									
R23		2			1 1/2			2		
R24			2	2					2	2
R25	2 1/2									
R26		2 1/2			2			2 1/2		
R27			2 1/2	2 1/2					2 1/2	2 1/2
R28					2 1/2					
R29	3									
R30		3								
R31		3	3					3	3	
R32					3					
R33	3 1/2									
R34		3 1/2								
R35				3						3
R36	4									
R37		4	4					4	4	3 1/2
R38					4					
R39				4						4
R40	5									
R41		5	5					5	5	
R42					5					
R43	6									
R44				5						5
R45		6	6					6	6	
R46				6						6
R47					6					
R48	8									
R49		8	8					8	8	
R50				8						8
R51					8					
R52	10									
R53		10	10					10	10	
R54				10						10
R55					10					
R56	12									
R57		12	12			12	12	12	12	

Type R Ring Joint gasket dimensional table according to standard ASME B16.47 Series A and API 6B

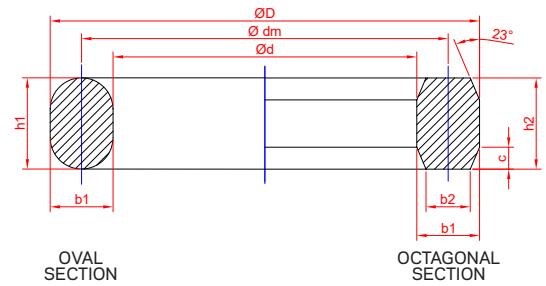

Type R	Nominal diameter									
	ASME/ANSI B16.5					ASME B16.47A		API 6B		
	Class 150	Class 300/600	Class 900	Class 1500	Class 2500	Class 300/600	Class 900	Class 2000	Class 3000	Class 5000
R58				12						
R59	14									
R60					12					
R61		14				14		14	14	
R62			14				14			
R63				14						
R64	16									
R65		16				16		16		
R66			16				16		16	
R67				16						
R68	18									
R69		18				18		18		
R70			18				18		18	
R71				18						
R72	20									
R73		20				20		20		
R74			20				20		20	
R75				20						
R76	24									
R77		24				24				
R78			24				24			
R79				24						
R80					22					
R81						22				
R82										1
R84										1 1/2
R85										2
R86										2 1/2
R87										3
R88										4
R89										3 1/2
R90										5
R91										10
R92										
R93						26				
R94						28				
R95						30				
R96						32				
R97						34				
R98						36				
R99								8	8	
R100							26			
R101							28			
R102							30			
R103							32			
R104							34			
R105							36			

Type R Ring Joint gasket dimensional table according to standard ASME B16.47 Series A and API 6B

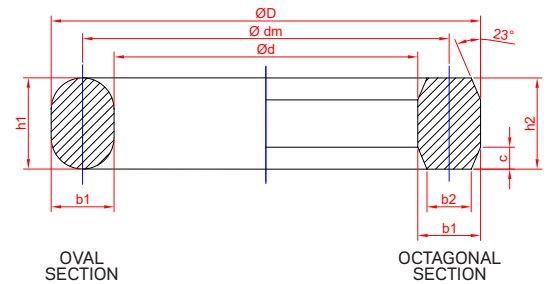

Type R	Dimension								OVAL gr	OCTAGONAL gr
	± 0,38 ØD(mm)	± 0,38 Ød(mm)	± 0,17 Ødm(mm)	± 0,39 h1(mm)	± 0,39 h2(mm)	± 0,20 b1(mm)	± 0,20 b2(mm)			
R11	40,49	27,79	34,14	11,18	9,65	4,32	4,32	50	50	
R12	47,65	31,75	39,7	14,22	12,7	7,95	5,23	100	100	
R13	50,83	34,93	42,88	14,22	12,7	7,95	5,23	100	100	
R14	52,4	36,5	44,45	14,22	12,7	7,95	5,23	110	110	
R15	55,58	39,68	47,63	14,22	12,7	7,95	5,23	120	120	
R16	58,75	42,85	50,8	14,22	12,7	7,95	5,23	120	110	
R17	65,1	49,2	57,15	14,22	12,7	7,95	5,23	140	130	
R18	62,28	52,38	60,33	14,82	12,7	7,95	5,23	150	140	
R19	73,05	57,15	65,1	14,82	12,7	7,95	5,23	160	150	
R20	76,23	60,33	68,28	14,82	12,7	7,95	5,23	170	150	
R21	83,37	61,11	72,24	17,53	16	11,13	7,75	300	290	
R22	90,5	74,6	82,55	14,82	12,7	7,95	5,23	200	190	
R23	93,68	71,42	82,55	17,53	16	11,13	7,75	340	330	
R24	106,38	84,12	95,25	17,53	16	11,13	7,75	390	380	
R25	109,55	93,65	101,6	14,22	12,7	7,95	5,23	250	230	
R26	112,73	90,47	101,6	17,53	16	11,13	7,75	420	410	
R27	119,08	96,82	107,95	19,05	16	11,13	7,75	450	430	
R28	123,87	98,43	111,13	14,22	17,53	12,7	8,66	570	550	
R29	122,25	107,95	114,3	17,53	12,7	7,95	5,23	280	260	
R30	128,61	106,35	117,48	17,53	16	11,13	7,75	480	470	
R31	134,96	112,7	123,85	17,53	16	11,13	7,75	510	500	
R32	139,7	114,3	127	19,05	17,53	12,7	8,66	650	630	
R33	139,73	123,83	131,78	14,22	12,7	7,95	5,23	320	300	
R34	142,91	120,65	131,78	17,53	16	11,13	7,75	540	520	
R35	147,66	125,4	136,53	17,53	16	11,13	7,75	560	550	
R36	157,18	141,28	149,23	14,22	12,7	7,95	8,23	370	340	
R37	160,36	138,1	149,23	17,53	16	11,13	7,75	620	600	
R38	173,06	141,3	157,18	22,35	20,57	15,88	10,49	1160	1140	
R39	173,06	150,8	161,93	17,53	16	11,13	7,75	670	650	
R40	179,4	163,5	171,45	14,22	12,7	7,95	5,23	420	390	
R41	192,11	169,85	180,98	17,53	16	11,13	7,75	750	730	
R42	209,55	171,45	190,5	24,4	23,88	19,05	12,32	1910	1880	
R43	201,63	185,73	193,68	14,22	12,7	7,95	5,23	480	440	
R44	204,81	182,55	193,68	17,53	16	11,13	7,75	800	780	
R45	222,28	200,02	211,15	17,53	16	11,13	7,75	870	850	
R46	223,85	198,45	211,15	19,05	17,53	12,7	8,66	1080	1050	
R47	247,65	209,55	228,6	25,4	23,88	19,05	12,32	2290	2260	
R48	255,6	239,7	247,65	14,22	12,7	7,95	5,23	610	560	
R49	281,01	258,75	269,88	17,53	16	11,13	7,75	1110	1090	
R50	285,76	254	269,88	22,35	20,57	15,88	10,49	1990	1950	
R51	301,63	257,17	279,4	28,7	26,92	22,23	14,81	3650	3690	
R52	312,75	296,85	304,8	14,22	12,7	7,95	5,23	750	690	
R53	334,98	312,72	323,85	17,53	16	11,13	7,75	1340	130	
R54	339,73	307,97	323,85	22,35	20,57	15,88	10,49	2390	2350	
R55	371,48	314,32	342,9	36,58	35,05	28,58	19,81	7350	7680	
R56	388,95	373,05	381	14,22	12,7	7,95	5,23	930	870	
R57	392,13	369,87	381	17,53	16	11,13	7,75	1570	1530	

Type R Ring Joint gasket dimensional table according to standard ASME B16.47 Series A and API 6B

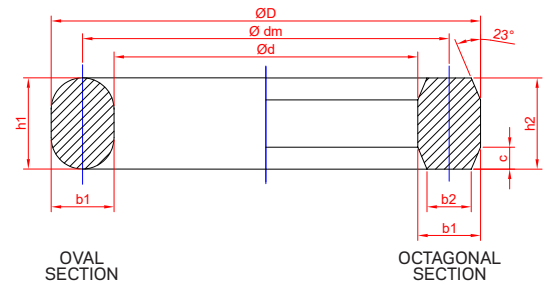

Type R	Dimension								OVAL gr	OCTAGONAL gr
	± 0,38 ØD(mm)	± 0,38 Ød(mm)	± 0,17 Ødm(mm)	± 0,39 h1(mm)	± 0,39 h2(mm)	± 0,20 b1(mm)	± 0,20 b2(mm)			
R58	403,23	358,77	381	28,7	26,92	22,23	14,81	4980	5030	
R59	404,83	388,93	396,88	14,22	12,7	7,95	5,23	960	900	
R60	438,15	374,65	406,4	39,62	38,1	31,75	22,33	10470	11090	
R61	430,23	407,97	419,1	17,53	16	11,13	7,75	1730	1690	
R62	434,98	403,22	419,1	22,35	20,57	15,88	10,49	3090	3040	
R63	444,5	393,7	419,1	33,27	31,75	25,4	17,3	7330	7540	
R64	461,98	446,08	454,03	14,22	12,7	7,95	5,21	1120	1030	
R65	481,03	458,77	469,9	17,53	16	11,13	7,75	1940	1890	
R66	485,78	454,02	469,9	22,35	20,57	15,88	10,49	3470	3400	
R67	498,48	441,32	469,9	36,58	35,05	28,58	19,81	10070	10530	
R68	525,48	509,58	517,53	14,22	12,7	7,95	5,23	1280	1180	
R69	544,53	522,27	533,4	17,53	16	11,13	7,75	2200	2150	
R70	522,45	514,35	533,4	25,4	23,88	19,05	12,32	5350	5270	
R71	561,98	504,82	533,4	36,58	35,05	28,58	19,81	11430	11950	
R72	566,75	550,85	558,8	14,22	12,7	7,95	5,23	1380	1270	
R73	596,9	571,5	584,2	19,05	17,53	12,7	8,66	2990	2920	
R74	603,25	565,15	584,2	25,4	23,88	19,05	12,32	5850	5770	
R75	615,95	552,45	584,2	39,62	38,1	31,75	22,33	15050	15940	
R76	681,05	665,15	673,1	14,22	12,7	7,95	5,23	1660	1530	
R77	708,03	676,27	692,15	22,35	20,57	15,88	10,49	5110	5010	
R78	717,55	666,75	692,15	33,27	31,75	25,4	17,3	12100	12460	
R79	727,08	657,22	692,15	44,45	41,4	34,93	24,82	22580	22060	
R80	623,9	608	615,95	-	12,7	7,95	5,23	-	1400	
R81	649,3	620,7	635	-	19,05	14,3	9,58	-	3860	
R82	66,28	46,02	57,15	-	16	11,13	7,75	-	230	
R84	74,63	52,37	63,5	-	16	11,13	7,75	-	250	
R85	92,08	66,68	79,38	-	17,53	12,7	8,66	-	400	
R86	106,38	74,52	90,5	-	20,57	15,88	10,49	-	650	
R87	115,91	84,15	100,03	-	20,57	15,88	10,49	-	720	
R88	142,88	104,78	123,83	-	23,88	19,05	12,32	-	1220	
R89	133,35	95,25	114,3	-	23,88	19,05	12,32	-	1130	
R90	177,81	133,35	155,58	-	26,92	22,23	14,81	-	2050	
R91	292,1	228,6	260,35	-	38,1	31,75	22,33	-	7100	
R92	239,73	217,47	228,6	17,53	16	11,13	7,75	0,94	920	
R93	768,35	730,25	749,3	-	23,88	19,05	12,32	-	7400	
R94	819,15	781,05	800,1	-	23,88	19,05	12,32	-	7900	
R95	876,3	838,2	857,25	-	23,88	19,05	12,32	-	8470	
R96	936,63	892,17	914,4	-	26,92	22,23	14,81	-	12080	
R97	987,43	942,97	955,2	-	26,92	22,23	14,81	-	12750	
R98	1044,58	1000,12	1022,35	-	26,92	22,23	14,81	-	13510	
R99	246,08	223,82	234,95	-	16	11,13	7,75	-	950	
R100	777,88	720,72	749,3	-	35,05	28,58	19,81	-	16790	
R101	831,85	768,35	800,1	-	38,1	31,75	22,33	-	21830	
R102	889	825,5	857,25	-	38,1	31,75	22,33	-	23390	
R103	946,15	882,65	914,4	-	38,1	31,75	22,33	-	24950	
R104	1000,13	930,27	966,2	-	41,4	36,93	24,82	-	31490	
R105	1057,28	987,42	1022,35	-	41,4	34,93	24,82	-	33350	

Type RX Ring Joint gasket dimensional table according to Standard ASME B16.47 API 6A

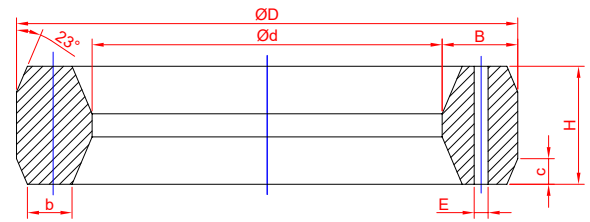

Type RX	Nominal diameter				
	API Std 6A				
	2000	3000	5000	2900	5000
RX20	1 1/2	1 1/2	1 1/2		2 1/16
RX23	2				
RX24		2	2		
RX25			3 1/8		3 1/8
RX26	2 1/12				
RX27		2 1/2	2 1/2		
RX31	3	3			
RX35			3		
RX37	4	4			
RX39			4		
RX41	5	5			
RX44			5		
RX45	6	6			
RX46			6		
RX47			8*		
RX49	8	8			
RX50			8		
RX53	10	10			
RX54			10		
RX57	12	12			
RX63			14		
RX65	16				
RX66		16			
RX69	18				
RX70		18			
RX73	20				
RX74		20			
RX82				1	
RX84				1 1/2	
RX85				2	
RX86				2 1/2	
RX87				3	
RX88				4	
RX89				3 1/2	
RX90				5	
RX91				10	
RX99	8*	8*			
RX201			1 3/8		1 1/8 A
RX205			1 13/16		1 9/16 A
RX215			4 1/16		4 1/16 A

Type BX Ring Joint gasket dimensional table according to Standard API 6A

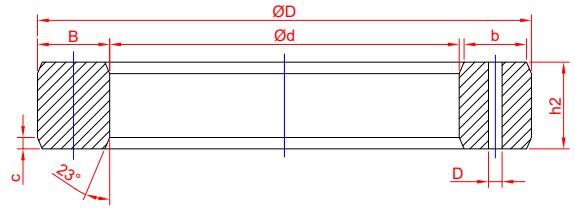

Type R	Dimension								PESO gr
	0/+0,5 ØD(mm)	0/+0,5 Ød(mm)	0/+0,2 H(mm)	0/+0,2 B(mm)	0/+0,15 b(mm)	0/-0,79 c(mm)	±0,39 r1(mm)	* E(mm)	
RX20	76,2	58,72	19,05	8,74	4,62	3,17	1,52	-	240
RX23	93,27	69,45	25,4	11,91	6,45	4,24	1,59	-	520
RX24	105,97	82,15	25,4	11,91	6,45	4,24	1,59	-	600
RX25	109,55	92,07	19,05	8,74	4,62	3,17	1,59	-	500
RX26	111,91	88,09	25,4	11,91	6,45	4,24	1,59	-	640
RX27	118,26	94,44	25,4	11,91	6,45	4,24	1,59	-	680
RX31	134,54	110,72	25,4	11,91	6,45	4,24	1,59	-	780
RX35	147,24	123,42	25,4	11,91	6,45	4,24	1,59	-	860
RX37	159,94	136,12	25,4	11,91	6,45	4,24	1,59	-	950
RX39	172,64	148,82	25,4	11,91	6,45	4,24	1,59	-	1030
RX41	191,69	167,87	25,4	11,91	6,45	4,24	1,59	-	1150
RX44	204,39	180,57	25,4	11,91	6,45	4,24	1,59	-	1230
RX45	221,84	198,02	25,4	11,91	6,45	4,24	1,59	-	1340
RX46	222,25	195,27	28,58	13,49	6,68	4,77	1,59	-	1660
RX47	245,26	205,58	41,28	19,84	10,34	6,88	2,29	-	3880
RX49	280,59	256,77	25,4	11,91	6,45	4,24	1,52	-	1720
RX50	283,36	250,04	31,75	16,66	8,51	5,28	1,59	-	2430
RX53	334,57	310,75	25,4	11,91	6,45	4,24	1,59	-	2060
RX54	337,34	304,02	31,75	16,66	8,51	5,28	1,59	-	2920
RX57	391,72	367,9	25,4	11,91	6,45	4,24	1,59	-	2420
RX63	441,73	387,73	50,8	27	14,78	8,45	2,29	-	11960
RX65	480,62	456,8	25,4	11,91	6,45	4,24	1,52	-	3000
RX66	457,99	424,67	31,75	16,66	8,51	5,28	1,59	-	4250
RX69	544,12	520,3	25,4	11,91	6,45	4,24	1,59	-	3410
RX70	550,06	510,38	41,28	19,84	10,34	6,88	2,29	-	9120
RX73	596,11	569,13	31,75	13,49	6,68	5,28	1,52	-	5270
RX74	600,86	561,18	41,28	19,84	10,34	6,88	2,29	-	10010
RX82	67,87	44,05	25,4	11,91	6,45	4,24	1,52	1,6	360
RX84	74,22	50,4	25,4	11,91	6,45	4,24	1,59	1,6	400
RX85	90,09	63,11	25,4	13,49	6,68	4,24	1,59	1,6	400
RX86	103,58	73,4	28,58	15,09	8,51	4,77	1,59	2,4	810
RX87	113,11	82,93	28,58	15,09	8,51	4,77	1,59	2,4	900
RX88	139,29	104,33	31,75	17,48	10,34	5,28	1,59	3,2	1460
RX89	129,77	93,25	31,75	18,26	10,34	5,28	1,59	3,2	3090
RX90	174,63	134,95	44,45	19,84	12,17	7,41	2,29	3,2	7750
RX91	286,94	226,58	45,24	30,18	19,81	7,54	2,29	3,2	1500
RX99	245,67	221,85	25,4	11,91	6,45	4,24	1,52	-	2200
RX201	51,46	39,98	11,3	5,74	3,2	1,44	0,51	-	100
RX205	62,31	51,19	11,1	5,56	3,05	1,82	0,51	-	130
RX215	140,89	117,07	25,4	11,91	5,33	4,24	1,52	-	800

Notes:

The hole shall be built at the centre of the dimension b
 [*] valid for cross over flange connections

Type BX Ring Joint gasket dimensional table according to Standard API 6A

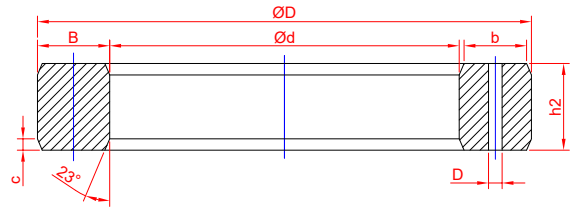

Type BX	Nominal diameter					
	API Std 6A					
	2000	3000	5000	10000	15000	20000
BX150				1 11/16	1 11/16	
BX151				1 13/16	1 13/16	1 13/16
BX152				2 1/16	2 1/16	2 1/16
BX153				2 9/16	2 9/16	2 9/16
BX154				3 1/16	3 1/16	3 1/16
BX155				4 1/16	4 1/16	4 1/16
BX156				7 1/16	7 1/16	7 1/16
BX157				9	9	9
BX158				11	11	11
BX159				13 5/8	13 5/8	13 5/8
BX160			13 5/8			
BX161			16 3/4			
BX162			16 3/4	16 3/4	16 3/4	
BX163			18 3/4			
BX164				18 3/4	18 3/4	
BX165			21 1/4			
BX166				21 1/4		
BX167	26 3/4					
BX168		26 3/4				
BX169				5 1/8		
BX170				6 5/8	6 5/8	
BX171				8 9/16	8 9/16	
BX172				11 5/32	11 5/32	
BX303	30	30				

* The R radius should be 8-12% of h2 dimensions. The D hole must be in the middle of the b dimension

Type BX	Dimension						WEIGHT gr
	0/+0,15 ØD(mm)	0/+0,15 Ød(mm)	0/+0,2 h2(mm)	0/+0,2 B(mm)	0/-0,15 b(mm)	* D(mm)	
BX150	72,19	53,59	9,3	9,3	7,98	1,52	130
BX151	76,40	57,14	9,63	9,63	8,26	1,52	150
BX152	84,68	64,20	10,24	8,79	83,24	1,52	190
BX153	100,94	78,18	11,38	11,38	9,78	1,52	290
BX154	116,84	92,04	12,40	12,40	10,64	1,52	400
BX155	147,96	119,52	14,22	14,22	12,22	1,52	550
BX156	237,92	200,68	18,62	18,62	15,98	1,52	1.870
BX157	294,46	252,50	20,98	20,98	18,01	3,05	2.970
BX158	352,04	305,76	23,14	23,14	19,86	3,05	4.350
BX159	426,72	375,32	25,70	25,70	22,07	3,05	6.530
BX160	402,59	375,11	23,83	13,74	10,36	3,05	3.060
BX161	491,41	458,99	28,07	16,21	12,24	3,05	5.350
BX162	475,49	447,05	14,22	14,22	12,22	1,52	1.940
BX163	556,16	521,42	30,10	17,37	13,11	3,05	6.900
BX164	570,56	521,38	30,10	24,59	20,32	3,05	5.860
BX165	624,71	587,71	32,02	18,49	13,97	3,05	8.760
BX166	640,03	587,75	32,03	26,14	21,62	3,05	12.820
BX167	759,36	733,14	35,86	13,11	8,03	1,52	8.530
BX168	765,25	733,15	35,86	16,05	10,97	1,52	10.540
BX169	173,51	147,65	15,85	12,93	10,69	1,52	730
BX170	218,03	189,59	14,22	14,22	12,22	1,52	1.030
BX171	267,44	239,00	14,22	14,22	12,22	1,52	1.240
BX172	333,07	304,63	14,22	14,22	12,22	1,52	1.560
BX303	852,75	818,80	37,94	16,98	11,60	1,60	13.180

Insulation solutions

Insulation Kit, Insulation Kit FSA,
Anticorrosion Kit

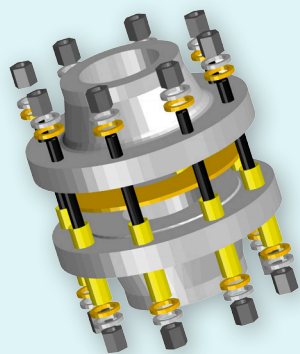

INSULATION KIT

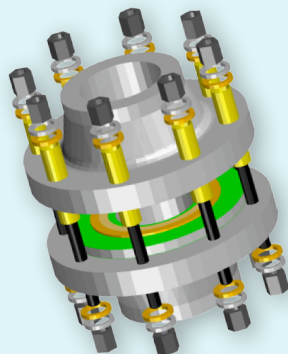

INSULATION KIT FSA

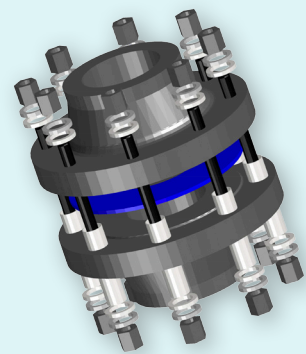

ANTICORROSION KIT

Insulation Kit dimensional table for flanges according to Standard ANSI B16.5

Serie 150		Ø Type F	Ø Type E	Sleeve					Sleeve					Washers		Bolts		
INCH.	Ø int	Ø EXT	Ø EXT	th.	dn int	DN EXT	lung	n.	th.	dn int	DN EXT	lung	n.	dn int	DN EXT	th.	n.	n.
INCH.	Ø int	Ø EXT	Ø EXT	th.	dn int	DN EXT	lung	n.	th.	dn int	DN EXT	lung	n.	dn int	DN EXT	th.	n.	n.
1/2	12,7	45,7	88,9	6,6	12,8	15,1	41,7	4	3	12,8	15,1	38,2	4	15,7	28,6	3	8+8	4
3/4	19,1	55,2	98,43	6,6	12,8	15,1	44,7	4	3	12,8	15,1	41,3	4	15,7	28,6	3	8+8	4
1	25,4	64,8	107,95	6,6	12,8	15,1	47,8	4	3	12,8	15,1	44,3	4	15,7	28,6	3	8+8	4
1-1/4	31,8	74,3	117,48	6,6	12,8	15,1	50,8	4	3	12,8	15,1	47,9	4	15,7	28,6	3	8+8	4
1-1/2	38,1	83,8	127	6,6	12,8	15,1	54	4	3	12,8	15,1	50,9	4	15,7	28,6	3	8+8	4
2	52,5	101,6	152,4	6,6	16	18,3	57,4	4	3	16	18,3	54	4	18,7	33,3	3	8+8	4
2-1/2	62,7	120,7	177,8	6,6	16	18,3	63,6	4	3	16	18,3	60,6	4	18,7	33,3	3	8+8	4
3	77,9	133,4	190,5	6,6	16	18,3	67,1	4	3	16	18,3	63,6	4	18,7	33,3	3	8+8	4
4	102,3	171,5	228,6	6,6	16	18,3	67,1	8	3	16	18,3	63,6	8	18,7	33,3	3	16+16	8
5	128,2	193,7	254	6,6	19,2	21,5	67,1	8	3	19,2	21,5	63,6	8	22	38,1	3	16+16	8
6	154,1	219,1	279,4	6,6	19,2	21,5	70,1	8	3	19,2	21,5	66,7	8	22	38,1	3	16+16	8
8	202,7	276,2	342,9	6,6	19,2	21,5	76,2	8	3	19,2	21,5	73,3	8	22	38,1	3	16+16	8
10	254,5	336,6	406,4	6,6	22,4	24,6	79,4	12	3	22,4	24,6	76,3	12	25,1	42,9	3	24+24	12
12	304,8	406,4	482,6	6,6	22,4	24,6	82,8	12	3	22,4	24,6	79,4	12	25,1	42,9	3	24+24	12
14	336,6	447,7	533,4	6,6	25,5	27,8	89	12	3	25,5	27,8	86	12	28,3	47,6	3	24+24	12
16	387,4	511,2	596,9	6,6	25,5	27,8	92,5	16	3	25,5	27,8	89	16	28,3	47,6	3	32+32	16
18	438,2	546,1	635	6,6	28,7	31	98,6	16	3	28,7	31	95,1	16	31,4	50,8	3	32+32	16
20	489,0	603,3	698,5	6,6	28,7	31	104,8	20	3	28,7	31	101,7	20	31,4	50,8	3	40+40	20
24	590,6	714,4	812,8	6,6	31,9	34,2	114,4	20	3	31,9	34,2	111,4	20	34,5	57,2	3	40+40	20

serie 300		Ø Type F	Ø Type E	sleeve					sleeve					washers		bolts		
INCH.	Ø int	Ø EXT	Ø EXT		dn int	DN EXT	lung	n.	th.	dn int	DN EXT	lung	n.	dn int	DN EXT	th.	n.	n.
1/2	12,7	52,1	95,25	6,6	12,8	15,1	47,8	4	3	12,8	15,1	44,3	4	15,7	28,6	3	8+8	4
3/4	19,1	64,8	117,48	6,6	16	18,3	50,8	4	3	16	18,3	47,9	4	18,7	33,3	3	8+8	4
1	25,4	71,1	123,83	6,6	16	18,3	54	4	3	16	18,3	50,9	4	18,7	33,3	3	8+8	4
1-1/4	31,8	80,6	133,35	6,6	16	18,3	57,4	4	3	16	18,3	54	4	18,7	33,3	3	8+8	4
1-1/2	38,1	93,3	155,58	6,6	19,2	21,5	60,5	4	3	19,2	21,5	57	4	22	38,1	3	8+8	4
2	52,5	108	165,1	6,6	16	18,3	63,6	8	3	16	18,3	60,6	8	18,7	33,3	3	16+16	8
2-1/2	62,7	127	190,5	6,6	19,2	21,5	70,1	8	3	19,2	21,5	66,7	8	22	38,1	3	16+16	8
3	77,9	146,1	209,55	6,6	19,2	21,5	76,2	8	3	19,2	21,5	73,3	8	22	38,1	3	16+16	8
4	102,3	177,8	254	6,6	19,2	21,5	82,8	8	3	19,2	21,5	79,4	8	22	38,1	3	16+16	8
5	128,2	212,7	279,4	6,6	19,2	21,5	89	8	3	19,2	21,5	86	8	22	38,1	3	16+16	8
6	154,1	247,7	317,5	6,6	19,2	21,5	92,5	12	3	19,2	21,5	89	12	22	38,1	3	24+24	12
8	202,7	304,8	381	6,6	22,4	24,6	101,6	12	3	22,4	24,6	98,7	12	25,1	42,9	3	24+24	12
10	254,5	358,8	444,5	6,6	25,5	27,8	114,4	16	3	25,5	27,8	111,4	16	28,3	47,6	3	32+32	16
12	304,8	419,1	520,7	6,6	28,7	31	120,9	16	3	28,7	31	117,4	16	31,4	50,8	3	32+32	16
14	336,6	482,6	584,2	6,6	28,7	31	127	20	3	28,7	31	124,1	20	31,4	50,8	3	40+40	20
16	387,4	536,6	647,7	6,6	31,9	34,2	133,6	20	3	31,9	34,2	130,2	20	34,5	57,2	3	40+40	20
18	438,2	593,7	711,2	6,6	31,9	34,2	139,8	24	3	31,9	34,2	136,8	24	34,5	57,2	3	48+48	24
20	489,0	650,9	774,7	6,6	31,9	34,2	146,3	24	3	31,9	34,2	142,9	24	34,5	57,2	3	48+48	24
24	590,6	771,5	914,4	6,6	38,2	40,5	159	24	3	38,2	40,5	155,6	24	41,4	69,9	3	48+48	24

Insulation Kit dimensional table for flanges according to Standard ANSI B16.5

serie 600		Ø Type F	Ø Type E	sleeve					sleeve					washers			bolts	
INCH.	Ø int	Ø EXT	Ø EXT		dn int	DNEXT	lungn	n.	th.	dn int	DNEXT	lungn	n.	dn int	DNEXT	th.	n.	n.
1/2	12,7	52,1	95,25	6,6	12,8	15,1	58,9	4	3	12,8	15,1	57	4	15,7	28,6	3	8+8	4
3/4	19,1	64,8	117,48	6,6	16	18,3	63,5	4	3	16	18,3	60,6	4	18,7	33,3	3	8+8	4
1	25,4	71,1	123,83	6,6	16	18,3	67,1	4	3	16	18,3	63,6	4	18,7	33,3	3	8+8	4
1-1/4	31,8	80,6	133,35	6,6	16	18,3	73,2	4	3	16	18,3	69,7	4	18,7	33,3	3	8+8	4
1-1/2	38,1	93,3	155,58	6,6	19,2	21,5	76,7	4	3	19,2	21,5	73,3	4	22	38,1	3	8+8	4
2	52,5	108	165,1	6,6	16	18,3	82,8	8	3	16	18,3	79,4	8	18,7	33,3	3	16+16	8
2-1/2	62,7	127	190,5	6,6	19,2	21,5	88,9	8	3	19,2	21,5	86	8	22	38,1	3	16+16	8
3	77,9	146,1	209,55	6,6	19,2	21,5	95,5	8	3	19,2	21,5	92,1	8	22	38,1	3	16+16	8
4	102,3	190,5	273,05	6,6	22,4	24,6	108,2	8	3	22,4	24,6	104,8	8	25,1	42,9	3	16+16	8
5	128,2	238,1	279,4	6,6	25,5	27,7	120,9	8	3	25,5	27,7	117,5	8	28,3	47,6	3	16+16	8
6	154,1	263,5	355,6	6,6	25,5	27,8	127,5	12	3	25,5	27,8	124,1	12	28,3	47,6	3	24+24	12
8	202,7	317,5	419,1	6,6	28,7	31	143,3	12	3	28,7	31	139,8	12	31,4	50,8	3	24+24	12
10	254,5	396,9	508	6,6	31,9	34,2	159	16	3	31,9	34,2	155,6	16	34,5	57,2	3	32+32	16
12	304,8	454	558,8	6,6	31,9	34,2	165,1	20	3	31,9	34,2	162,2	20	34,5	57,2	3	40+40	20
14	336,6	489	603,25	6,6	35,1	37,3	171,7	20	3	35,1	37,3	168,3	20	38,1	63,5	3	40+40	20
16	387,4	562	685,8	6,6	38,2	40,5	184,4	20	3	38,2	40,5	181	20	41,4	69,9	3	40+40	20
18	438,2	609,6	742,95	6,6	41,4	43,7	197,1	20	3	41,4	43,7	193,7	20	41,4	43,7	3	40+40	20
20	489,0	679,5	812,8	6,6	41,4	43,7	209,8	24	3	41,4	43,7	206,4	24	44,1	76,2	3	48+48	24
24	590,6	787,4	939,8	6,6	47,8	50	235,2	24	3	47,8	50	231,8	24	51,2	86,1	3	48+48	24

serie 900		Ø Type F	Ø Type E	sleeve					sleeve					washers			bolts	
INCH.	Ø int	Ø EXT	Ø EXT		dn int	DNEXT	lungn	n.	th.	dn int	DNEXT	lungn	n.	dn int	DNEXT	th.	n.	n.
1/2	12,7	61,6	120,65	6,6	19,2	21,5	76,7	4	3					22	38,1	3	8+8	4
3/4	19,1	67,9	130,18	6,6	19,2	21,5	82,8	4	3					22	38,1	3	8+8	4
1	25,4	77,5	149,23	6,6	22,4	24,6	88,9	4	3					25,1	42,9	3	8+8	4
1-1/4	31,8	87	158,75	6,6	22,4	24,6	88,9	4	3					25,1	42,9	3	8+8	4
1-1/2	38,1	96,5	177,8	6,6	25,5	27,8	95,5	4	3					28,3	47,6	3	8+8	4
2	52,5	139,7	215,9	6,6	22,4	24,6	108,2	8	3					25,1	42,9	3	16+16	8
2-1/2	62,7	161,9	244,48	6,6	25,5	27,8	114,3	8	3					28,3	47,6	3	16+16	8
3	77,9	165,1	241,3	6,6	22,4	24,6	108,2	8	3					25,1	42,9	3	16+16	8
4	102,3	203,2	292,1	6,6	28,7	31	120,9	8	3					28,7	31	3	16+16	8
5	128,2	244,5	349,25	6,6	31,9	34,2	133,6	8	3					34,5	57,2	3	16+16	8
6	154,1	285,8	381	6,6	28,7	31	143,3	12	3					31,4	50,8	3	24+24	12
8	202,7	355,6	469,9	6,6	35,1	37,3	159	12	3					38,1	63,5	3	24+24	12
10	454,5	431,8	546,1	6,6	35,1	37,3	171,7	16	3					38,1	63,5	3	32+32	16
12	304,8	495,3	609,6	6,6	35,1	37,3	190,5	20	3					38,1	63,5	3	40+40	20
14	336,6	517,5	641,35	6,6	38,2	40,5	203,7	20	3					41,4	69,9	3	40+40	20
16	387,4	571,5	704,85	6,6	41,4	43,7	209,8	20	3					44,1	76,2	3	40+40	20
18	438,2	635	787,4	6,6	47,8	50	235,2	20	3					51,2	86,1	3	40+40	20
20	489,0	695,3	857,25	6,6	50,9	53,2	247,9	20	3					53,6	95,3	3	40+40	20
24	590,6	835	1041,4	6,6	63,6	65,9	311,4	20	3					66,7	114,3	3	40+40	20

Insulation Kit dimensional table for flanges according to Standard ANSI B16.5

serie 1500		Ø Type F	Ø Type E	sleeve					sleeve					washers		bolts		
INCH.	Ø int	Ø EXT	Ø EXT		dn int	DNEXT	lungh	n.	th.	dn int	DNEXT	lungh	n.	dn int	DNEXT	th.	n.	n.
1/2	12,7	61,6	120,65	6,6	19,2	21,5	76,7	4	3					22	38,1	3	8+8	4
3/4	19,1	67,9	130,18	6,6	19,2	21,5	82,8	4	3					22	38,1	3	8+8	4
1	25,4	77,5	149,23	6,6	22,4	24,6	88,9	4	3					25,1	42,9	3	8+8	4
1-1/4	31,8	87	158,75	6,6	22,4	24,6	88,9	4	3					25,1	42,9	3	8+8	4
1-1/2	38,1	96,5	177,8	6,6	25,5	27,8	95,5	4	3					28,3	47,6	3	8+8	4
2	52,5	139,7	215,9	6,6	22,4	24,6	108,2	8	3					25,1	42,9	3	16+16	8
2-1/2	62,7	161,9	244,48	6,6	25,5	27,8	114,3	8	3					28,3	47,6	3	16+16	8
3	77,9	171,5	266,7	6,6	28,7	31	127,5	8	3					31,4	50,8	3	16+16	8
4	102,3	206,4	311,15	6,6	31,9	34,2	139,7	8	3					34,5	57,2	3	16+16	8
5	128,2	250,8	374,65	6,6	38,2	40,5	178,3	8	3					41,4	69,9	3	16+16	8
6	154,1	279,4	393,7	6,6	28,7	31	197,1	12	3					31,4	50,8	3	24+24	12
8	202,7	349,3	482,6	6,6	41,4	43,7	215,9	12	3					44,1	76,2	3	24+24	12
10	254,5	431,8	584,2	6,6	47,8	50	247,9	12	3					51,2	86,1	3	24+24	12
12	304,8	517,5	673,1	6,6	50,9	53,2	279,9	16	3					53,6	95,3	3	32+32	16
14	336,6	574,7	749,3	6,6	57,3	59,6	298,7	16	3					60,1	101,6	3	32+32	16
16	387,4	638,2	825,5	6,6	63,6	65,9	324,1	16	3					66,7	114,3	3	32+32	16
18	438,2	701,7	914,4	6,6	70	72,3	356,1	16	3					73	133,4	3	32+32	16
20	489,0	752,5	984,25	6,6	76,3	78,6	387,6	16	3					79,4	138,4	3	32+32	16
24	590,6	898,5	1168,4	6,6	89	91,3	438,4	16	3					92,1	165,1	3	32+32	16

serie 2500		Type F	Ø Type E	sleeve					sleeve					washers		bolts		
INCH.	Ø int	Ø EXT	Ø EXT		dn int	DNEXT	lungh	n.	th.	dn int	DNEXT	lungh	n.	dn int	DNEXT	th.	n.	n.
1/2	12,7	67,9	133,35	6,6	19,2	21,5	92,5	4	3					22	38,1	3	8+8	4
3/4	19,1	74,3	139,7	6,6	19,2	21,5	95,5	4	3					22	38,1	3	8+8	4
1	25,4	83,8	158,75	6,6	22,4	24,6	102,1	4	3					25,1	42,9	3	8+8	4
1-1/4	31,8	102,9	184,15	6,6	25,5	27,8	108,2	4	3					28,3	47,6	3	8+8	4
1-1/2	38,1	115,6	203,2	6,6	28,7	31	120,9	4	3					31,4	50,8	3	8+8	4
2	52,5	142,9	234,95	6,6	25,5	27,8	133,6	8	3					28,3	47,6	3	16+16	8
2-1/2	62,7	165,1	266,7	6,6	28,7	31	146,3	8	3					31,4	50,8	3	16+16	8
3	77,9	193,7	304,8	6,6	31,9	34,2	165,1	8	3					34,5	57,2	3	16+16	8
4	102,3	231,8	355,6	6,6	38,2	40,5	184,4	8	3					41,4	69,9	3	16+16	8
5	128,2	276,2	419,1	6,6	44,6	46,9	215,9	8	3					47,2	82,6	3	16+16	8
6	154,1	314,3	482,6	6,6	50,9	53,2	247,9	8	3					53,6	95,3	3	16+16	8
8	202,7	384,2	552,45	6,6	50,9	53,2	286	12	3					53,6	95,3	3	24+24	12
10	254,5	473,1	673,1	6,6	63,6	65,9	362,2	12	3					66,7	114,3	3	24+24	12
12	304,8	546,1	762	6,6	70	72,3	400,3	12	3					73	133,4	3	24+24	12



CF® Service s.r.l.

Via del Vetro, 13/15 - 30020 Marcon, (VE) - ITALY
Tel.: +39 041 4568562 | Fax: +39 041 5952900
E-mail: info@cfservice.eu

SS 114, nr. 100, Contrada Biggemi Priolo (SR), ITALY
Tel: +39 041 4568562
Fax: +39 041 5952900
E-mail: info@cfservice.eu

CF®RO Service s.r.l.

Str. Rahovei Nr. 18 - 100028 Ploiesti (PH) - ROMANIA
Tel.: +40 371 189 742, Fax: +40 372 250 170
E-mail: roinfo@cfservice.eu | www.cfservice.ro

CF® Servis Conta Metal San. ve Tic. Ltd. Şti.

Oruçreis Mh. Tekstilkent Cd. Tekstilkent Ticaret Merkezi Galeri
G1 10-AB İç Kapı 47 Cap 34325 Esenler/İstanbul - TURKEY
Ph: +90 212 438 38 32, Fax + 90 212 806 38 86
E-mail: cfconta@cfservice.eu | www.cfservice.it

www.cfservice.it

[linkedin.com/company/cf-service-srl](https://www.linkedin.com/company/cf-service-srl)